

# BY- LAWS & RULES



**2011 EDITION**

*THE FASTEST & SAFEST* GUN  
SPORT  
IN THE WORLD

## **2010-2011 Executive Officers**

**Chairman : Dave Livingston**

**Secretary: Dan Qualls    Treasurer: Miles Miller**

### **Introduction**

**The By-Laws and Rules contained in this book are the result of many years of development and modification to provide safe and fair regulations for all Fast Draw competitions. From the initial version of these regulations changes have been made over time to adapt to the evolution of equipment and to make competition more fair and enjoyable for all participants while maintaining our heritage of safety and good sportsmanship.**

**David Livingston, Chairman  
2010-2011**

# WORLD FAST DRAW ASSOCIATION, INC.

## WORLD FAST DRAW ASSOCIATION, INC. HANDBOOK, RULES & BY-LAWS TABLE OF CONTENTS

<b>PART I</b>	<b>BY-LAWS</b>	1
A.	Name and Purpose	1
B.	Goal	1
C.	Board of Directors	1
D.	Officers	2
E.	Term of Office	4
F.	Voting	5
G.	Membership	5
H.	Code of Ethics	6
<b>PART II</b>	<b>GENERAL REQUIREMENTS</b>	6
A.	Chairman Sanction	6
B.	Vice Chairman Sanction	8
C.	Bidding System	9
D.	Contestant Requirements	9
E.	Safety Rules	10
F.	Annual Awards	11
G.	Records	14
<b>PART III</b>	<b>EQUIPMENT REQUIREMENTS</b>	15
A.	General	15
B.	Gun	15
C.	Holster Open Style	16
D.	Holster Traditional Style	16
E.	Target and Timing Equipment	17
F.	Ammunition	20

<b>PART IV</b>	<b>COMPETITION RULES</b>	21
A.	General	21
B.	Scoring	23
C.	Events	27
D.	Traditional Style Contests Policy and Purpose	30
E.	Twisting Style Contests Policy and Purpose	30
F.	Open Style Contests Policy and Purpose	30
G.	Traditional Open Style	30
H.	Hollywood Division	31
<b>PART V</b>	<b>HOST REQUIREMENTS</b>	31
A.	Host Responsibilities	31
B.	Site Selection	32
C.	Site Preparation	32
D.	Dry Fire Area	33
<b>PART VI</b>	<b>ILLUSTRATION SECTION</b>	34
A.	Hammer Height	34
B.	Hammer Width	34
C.	Barrel Size	35
D.	Trigger Guard	35
E.	Barrel Length	36
F.	Holster Gauge	36
G.	Holster Open Style	37
H.	Holster Traditional Style	37
I.	Hand Clearance	38
J.	Double Target Layout	38
K.	Balloon Target	39
<b>PART VII</b>	<b>HISTORY OF OFFICERS OF W.F.D.A.</b>	40
<b>PART VIII</b>	<b>ARCHIVE OF CHAMPIONS</b>	41
	<b>LOADING FAST DRAW AMMUNITION</b>	45

<b>WAX CARTRIDGES</b>	45
<b>BLANK CARTRIDGES</b>	46
<b>HELPING OUT AT CONTESTS</b>	47
<b>STARTING A FAST DRAW CLUB</b>	47
<b>SPONSORSHIP CONTRACT</b>	48
<b>NOTES</b>	51

## **PART 1 BY-LAWS**

### **A. NAME AND PURPOSE**

The organization shall be called WORLD FASTDRAW ASSOCIATION INC., hereinafter referred to as W.F.D.A. or the Association. Its purpose is to govern, preserve and promote the sport of Fastdraw.

### **B. GOAL**

Its goal is to provide a safe, competitive and legitimate sport, which retains the tradition of the American West.

### **C. BOARD OF DIRECTORS**

The powers of the W.F.D.A shall be exercised, its property controlled, and its affairs conducted by the Board of Directors.

1. The board of Directors shall consist of the Executive Officers, a minimum of ten (10) Area Vice-Chairmen and the IROI (Int'l, Range Officers Institute) director.
2. The Chairman shall serve as Chairman of the Board of Directors.
3. It is mandatory that the Board meet once a year. The Chairman may convene a Board meeting no sooner than thirty (30) days after written notice has been given to each Board member.
4. The Board of Directors shall establish long-range goals for the W.F.D.A.
5. All proposals to amend or change the Rules & By-Laws must be printed in the "OFFICIAL PUBLICATION" at least thirty (30) days in advance to any voting.
6. Proposals to amend or change the Rules & By-Laws are to be voted on only at the first Board meeting of the year. Exceptions to this will be safety rules or proposals the Chairman, Secretary and Treasurer deem are of emergency nature, and they must be in complete agreement that an emergency vote is needed.
7. Proposals to amend or change the rules & B-Laws sent to the Chairman for publication must be worded into by-law form stating appropriate sections of the rule book and must be signed. Wording but not meaning of proposals may be amended before voting at the B.O.D. meeting, if agreeable to whoever made the proposal. The name of the member (s) making the proposal will be published with the proposal.
8. Only the Board shall approve or disapprove changes to the Rules & By-Laws. Each member of the Board shall have one (1) vote, except the Chairman who will only vote to break a tie and the IROI Director who is a Non voting member of the B.O.D. At least fifty (50) percent of the board must be present to vote.
9. A simple majority shall be required to approve any measure unless otherwise stipulated herein. At Board meetings votes by mail or telephone will not be accepted. Proxy votes shall not be allowed, except by alternates (D. 2 and 3), any member of the Board may designate an alternate to vote in their absence.

10. The Chairman may veto any changes to the By-Laws approved by the Board provided said veto occurs within fifteen (15) days after voting.

11. The Board may override a Chairman's veto if two-thirds(2/3) of the total Board, excluding the Chairman, vote to do so within the thirty (30) days of veto notification.

12. A member may challenge an amendment or change to the Rules & By-Laws by presenting a petition with seventy-five (75) signatures of members within sixty (60) days of the issuance of a new rule book or notification. The petition must be submitted to the Chairman. The Chairman has thirty (30) days to prepare a ballot and present the amendment or change to the general membership for vote. The amendment or change shall be enforced until voting is tallied and the results published. Each amendment or change must have a separate petition: **members** from any area can sign petitions.

13. Any change in safety Rules must be enforced immediately.

14. The Board shall have the authority to remove elected officials from office (by majority vote) if said officers are not abiding by all W.F.D.A. Rules & By-Laws: if said officers conduct themselves in a manner unbecoming of W.F.D.A. officers: if it is apparent they're not doing their job as set forth in W.F.D.A Rules & By-Laws: or if through their actions show that they are not supporting the W.F.D.A. and office held.

15. The board may authorize a change or addition to the Rule Book that is to benefit the shooters or the W.F.D.A. Association at any time during the current year, not have to wait till the following year.

#### **D. OFFICERS**

1. The executive Officers elected by the general membership are: the Chairman, Secretary, and Treasurer.

2. The Executive Officers will have the right to designate an alternate to represent their office at the board meeting if they are unable to attend. The designated alternate will have the same voting privileges. This will be accomplished by a letter of authorization.

3. A Vice Chairman for each designated area will be elected by the members who reside in that Vice Chairman's area. Vice Chairmen shall have authority over all sanctioned contests in their area. When absent, the Vice Chairman must appoint an alternate with the same duties to officiate at a contest. This will be accomplished by a letter of authorization.

4. The Chairman is the highest officer in the W.F.D.A. and is the spokesman. The Chairman is also Chairman of the Board of Directors and shall conduct all meetings. The Chairman may delegate authority to those representatives of the W.F.D.A. as needed to facilitate W.F.D.A. business.

5. An established Vice Chairman area may be changed if the Chairman and Vice Chairman of the area feel the adjustment is essential and beneficial to W.F.D.A. members.

5 An established Vice Chairman area may be changed if the Chairman and Vice Chairman of the area feel the adjustment is essential and beneficial to W.F.D.A. members.

6 .The Chairman may establish new Vice Chairman areas as needed to provide for geographical and representational situations.

7. The Executive officers and the Editor of Top Gun Magazine shall receive free entry fees (while in office) to any sanctioned contest. A Vice Chairman shall receive free entry fees (while in office) to any sanctioned contest held in the Vice Chairman's area. Alternates are not entitled to free entry fees.

8. The Chairman shall have the authority to:

A. Represent the F.F.D.A. in communications, transactions, and other arrangements with businesses, the public, communications media, contest hosts, contest sponsors, other shooting groups, federal, state and local government agencies and other persons, or groups for the purpose of conducting W.F.D.A. Business or furthering the sport of Fast Draw.

B. Sanction or refuse to sanction as specified in the document.

C. Remove a previously granted sanction at any time if contest conditions, specifications, and rules are ignored or violated.

D. Assign Board members and other volunteer W.F.D.A. members to committees and appoint committee Chairmen.

E. Initiate and publish rule changes.

F. Levy fines against competitors who argue with or abuse contest officials as specified in Part II, Section D, #8, of these By-Laws.

G. Remove a member from the W.F.D.A. as specified in this document.

H. Direct an audit of the W.F.D.A.'s financial records.

I. Direct Vice Chairmen and contest officials to follow the rules as stated herein. The Chairman has final authority in rule and policy interpretation and enforcement.

J. Appoint a Publicity Director to enhance the public image of Fast Draw. The Publicity Director will release regular reports to news media, gun magazines, and other publications regarding Fast Draw activities and other pertinent news.

K. Publish monthly "OFFICIAL PUBLICATIONS" to the membership.

L. The Chairman or Publicity Officer shall have exclusive right to designate complimentary PUBLICATIONS to whomever they deem favorable on behalf of the W.F.D.A. At the end of the year, recipients will be asked to indicate whether they wish to have the favor continued.

9. The Secretary shall:

A. Keep minutes of all W.F.D.A. meeting.

B. Keep an accurate up-to-date file on all W.F.D.A. members including name, address, and due date. Send each member a membership card.

C. Correspond with all members and others as specified by the Chairman.

D. Keep the Official rulebook accurate and up-to-date.

E. Conduct an annual Membership Drive Contest.

F. Assist the Chairman and Treasures as needed.

G. Act in the Chairman's place when the Chairman is absent.

10. The Treasurer shall:
  - A. Keep and maintain all financial records.
  - B. Submit a quarterly financial report to the membership.
  - C. Prepare or cause to be prepared Income Tax Statements, as needed.
  - D. Submit the W.F.D.A. financial records to the Chairman or designated audit team for audits as directed by the Board.
  - E. Act in the Chairman's place when the Chairman and Secretary are absent.
11. The Executive Officers shall not:
  - A. Override an official's decision made during a contest unless it involves policy or By-Law interpretations.
  - B. Remove a Vice Chairman or W.F.D.A. officer from office.
  - C. Use W.F.D.A. funds for any purpose other than official W.F.D.A. business.
  - D. Engage in any commercial activity or business for personal profit that may result in a conflict of interest with the W.F.D.A.
  - E. Hold office in any other Fast Draw Association or club while holding office in the W.F.D.A.
12. The Vice Chairman or his/her alternate shall:
  - A. Represent W.F.D.A. members who reside in their area in matters brought before the Board of Directors.
  - B. Act as head official at sanctioned contests in their area.
  - C. Shall collect contest results for Vice Chairman sanctioned contests, check scores for accuracy, publish the results in the TOP GUN MAG., and maintain Area Top Gun point standings.
  - D. The Vice Chairman shall post current overall standings of the Vice Chairman contests in his area, at all of the Vice Chairman contests in his area.
  - E. The Vice Chairman specifically has the following authority:
    1. To sanction or refuse an area sanction.
    2. To levy fines as specified in Part I, Section C, #8, herein.
    3. Remove an area sanction at any time if contest conditions, specifications, and rules contained in this document are ignored or violated.
    4. Initiate and publish rule changes.
13. The Vice Chairman or his/her alternate shall not:
  - A. Override an official's decision made during sanction contests unless it involves policy or by-law interpretation.
  - B. Use W.F.D.A. funds for any purpose other than official W.F.D.A. business.
  - C. Engage in any commercial activity or business for personal profit that may result in a conflict of interest with the W.F.D.A.

**E. TERM OF OFFICE**

1. The term of office for Executive Officers shall be two (2) years beginning January 1st of the next year.
2. \*\* The term of office for Area Vice Chairman shall be two (2) years beginning January 1st and ending December 31st of the next year.

3. All elected officers will be nominated in October and voted on in November.
4. There shall be no limit to terms an individual may hold an office.
5. There shall be a maximum of three (3) Executive Chairmen elected by the Board. The Executive Chairmen have no vote on the Board, but act only in an advisory capacity. They have no privileges as an elected officer and shall be invited to all Board meeting.

#### **F. VOTING**

1. All voting shall be conducted by official ballots by mail. The secretary will prepare a ballot for all Executive Officers and Vice-Chairmen candidates. Each area's ballots shall be a different color. Ballots will be sent directly to each member with an official pre-addressed return envelope. Only these envelopes and ballots can be used. These envelopes will be sent directly to a Notary Public chosen by the Chairman. The Notary Public will place a check next to the name of each member who voted, on a W.F.D.A. membership list by using the return address on the official envelope. Ballots will then be removed in a manner to keep them anonymous.
2. Each member of the W.F.D.A. shall have one vote and a maximum of two votes per family where family membership fees are paid.
3. All ballots will be mailed to a Notary Public. That individual will count the ballots and submit the results to the Executive Officers.
4. When voting for new officers, the members will be allowed thirty (30) days to return their ballots from the date they were sent to the members.
5. September 1st (postmarked by) is the specified deadline for new memberships and past due renewals to be eligible to participate in nominations and elections for that year.

#### **G. MEMBERSHIP**

**Membership Renewal** dues shall be \$45 per year plus \$15 insurance. **Total \$60**  
Additional Family Members ( spouse & children under 18) shall be \$20 plus \$10 insurance each, **Total \$30**. When children reach 18, they become a full member.  
**All membership dues are due on February 10th.**

**New members** receive a Rule Book, WFDA patch and lapel (hat) pin.

Year begins February 11th each year. Cost is \$45 + \$15 Insurance, \$10 Initiation fee **Total \$70**.

Additional Family Member is \$20, + \$10 Insurance, + \$10 Initiation fee, **Total \$40**.

**New members** paying dues on October 1st or later in the year will pay full amount. This will cover the balance of the current year plus the entire following year.

**All members must pay yearly insurance fees including Life Members.**

**Life membership was put on a moratorium until further notice!**

4. It is recommended, full members residing within the U.S. should also be a member of The National Rifle Association.

5. Full members residing out of the U.S. shall pay an extra \$5.00 Canadian, and all other countries \$20, to cover extra postage for Top Gun Magazine, Side Kick, Ect. mailings.

6. Any member who receives four (4) points in the Membership Drive shall receive a one (1) year free membership. To be used the following year.
7. Honorary membership status shall be conferred on non-shooters by the agreement of any two Executive Officers for extraordinary contribution to Fast Draw and their shooting sports. They shall pay no dues but shall have full membership rights until terminated at the request of the honorary member.
8. The W.F.D.A. agrees to send all members a "TOP GUN" magazine bi-monthly (One per family), except when new member signs up during a special promotion.
9. Each new member shall receive a membership card, patch, and rulebook.
10. After accepting membership in the W.F.D.A., the member agrees to:
  - A. Uphold all decisions made by the Board of Directors.
  - B. Follow W.F.D.A. rules at all times.
  - C. Honor contests sanctioned by the W.F.D.A.
  - D. **Encourage non-members to join the W.F.D.A.**
  - E. Back the W.F.D.A. in disciplining members who do not honor their obligations as set forth in the Rules & By-Laws.

## **H. CODE OF ETHICS**

W.F.D.A. Professional Fast Draw Artists should honor the following:

1. Make every effort to comply with all By-Laws of the W.F.D.A. as published and intended.
2. Conduct themselves at all times in a professional manner.
3. When attending non-W.F.D.A. functions, shall not represent on behalf of the W.F.D.A. unless authorized to do so
4. When endorsing a product, shall not allow their names to be used in such a manner as to misrepresent the quality of such product.
5. Among fellow competitors, shall exercise the common courtesy befitting Professional Fast Draw Artist and sportsmen.
6. By unanimous decision of the Executive Officers, contestants who repeatedly act in an un-sportsman like manner may have their membership revoked or be disqualified from further competition until they show a willingness to abide by W.F.D.A. rules and behave in a sportsmanlike manner. Censured contestants will be notified in writing before the next sanctioned contest.

## **PART II GENERAL REQUIREMENTS**

### **A. CHAIRMAN SANCTION**

1. A chairman sanction maybe granted when the following are supplied to the Chairman:
  - a. A sanction fee of \$200.00 plus \$10.00 per shooter (payable after first day of the contest).
  - b. A complete list of prizes and awards.
  - c. A list of events.
  - d. A date for the contest.

2. The granted prize structure shall be no less than \$3,000.00 in U.S. funds and paid out in U.S. funds, or local currency equivalence, in cash excluding trophies, merchandise, or other awards.
3. A minimum of ten (10) trophies in the Men's Division and five (5) in the Women's Division shall be awarded to the overall place winners.
4. An award shall be given to the first place winner in each event in the Men's and Women's Divisions.
5. The Men's and Women's Champion shall receive an emblem from the W.F.D.A. stating the contest, year and title.
6. Any sanction ( Chairman or Vice-Chairman) may be canceled under the following conditions:
  - a. Excessive timing equipment malfunctions.
  - b. Contest prizes and awards are not present at the close of a contest or are less than advertised in the latest "TOP GUN" magazine or official announcement.
  - c. The host fails to provide adequate facilities as specified in Part V.
  - d. The contest events are not as advertised in the latest "TOP GUN" MAGAZINE OR OFFICIAL ANNOUNCEMENT.
  - e. For failure to enforce W.F.D.A. Rules and By-Laws.
  - f. Any W.F.D.A. member who does not wish to compete in the contest after the cancellation of the sanction shall have his full entry fee returned by the individual, sponsor, or hosting organization.
7. There shall be at least two (2) weeks between Chairman sanctioned contests. Vice Chairman sanctioned contests may be held on the same weekend in any other noncontiguous area, or when held in conjunction with a Chairman Sanctioned contest. When Vice Chairman sanctioned contests are held in other Areas on the same weekend as any Chairman Sanctioned contest the Area Top Gun Points will not be tallied, but mission count point will be recognized. There will be no sanctions granted on the same weekend as The All-Around World Championship tournament.
8. All Chairman sanctioned contests shall be advertised in the "TOP GUN" at least thirty (30) days from date of postmark, and must contain all particulars for that contest. The contest will be executed as published in the "TOP GUN" magazine..
9. World or National titles require a \$200.00 sanction fee, plus \$10.00 per shooter (payable after first day of contest). The guaranteed prize structure shall be no less than \$5,000.00, in cash, excluding trophies, merchandise, or other awards. These titles to be granted for Chairman Sanction Contests **ONLY**, which meet all Chairman requirements.
10. After any sanction with a cash prize structure of \$5,000.00 or more has been granted, the sponsor will enter into a contract with the W.F.D.A. This contract guarantees prize money on the assigned dates. The sponsor may cancel a sanction no later than ninety (90) days prior to the scheduled championship in writing, without recourse.

11. Sanction Fees are non-refundable.
12. All contestants in Chairman Sanctioned contests shall be W.F.D.A. members.
13. There will be no Chairman Sanctions granted for the contest dates after the 2<sup>nd</sup> weekend in November and through the month of December.
14. All contest ads and contest results that are not sanctioned will require a \$30.00 fee per ¼ page **PER ISSUE** to publish in the “TOP GUN” MAGAZINE. . This rate is for members only.

## **B. VICE CHAIRMAN SANCTION**

All requirements and conditions for granting or canceling sanctions are the same as Chairman Sanctions with the following exceptions:

1. A Vice Chairman sanctions all Vice Chairman sanctioned contests in his/her area.
2. The sanction fee is \$30.00, plus a \$5.00 per shooter fee.
3. A Vice Chairman contest can be sanctioned with minimum of \$300.00 guaranteed prize structure, in U.S. funds and paid out in U.S. funds, or local currency equivalence, in cash, excluding awards, or by a percentage structure, excluding awards.
  - a. Percentage contests will be set as follows:
  - b. Men's Division- 1<sup>st</sup> 30%, 2<sup>nd</sup> 25%, 3<sup>rd</sup> 20%, 4<sup>th</sup> 15%, 5<sup>th</sup> 10%.  
Women's Division- 1<sup>st</sup> 50%, 2<sup>nd</sup> 30%, 3<sup>rd</sup> 20%.
4. A minimum of five (5) places in Men’s Division and three (3) places in the Women’s Division shall receive cash and trophies.
5. Vice Chairman sanctioned contests may not be held on the same weekend within any one area, except when held in conjunction with one another.
6. Make-ups will be allowed at Vice Chairman sanctioned contests only at the discretion of the host, and must be advertised in the “Official Publication”. Make-ups will be allowed only in a two-day contest and only on the second day.
7. All contestants in a Vice-Chairman contest **MUST** be a W.F.D.A. member, except when the contest is dual sanctioned with another organization. In case of a dual sanctioned Vice Chairman contest all contestants must be members in one of the participating organizations.
8. A Vice Chairman Contest, sanctioned by the World Fast Draw Association (W.F.D.A.) may be dual sanctioned with another Association. Upon request, membership cards showing member in good standing in one of the participating organizations **MUST** be shown. The 30-day grace period does not come into effect. Contestants **MUST** be paid up current to participate in ANY dual sanctioned contest. Any variation of W.F.D.A. rules must be included in all advertisements of the contest.

9. There will be no Vice Chairman Sanctions granted after the 2nd weekend in November and through the month of December. the month of December.
10. All Vice-Chairman sanction contests shall be advertised 30-days from date of contest and must contain all particulars for that contest, with the following conditions: If the contest misses the advertising deadline and the Chairman decides that contest may be sanctioned, providing all area members are notified within two (2) weeks prior of said contest, the contest may be sanctioned.

### **C. BIDDING SYSTEM**

The current sponsor of a sanctioned championship will be guaranteed a fair chance to retain the sponsorship of the same title for the following year. The following bid system is for this purpose:

1. The current sponsor shall submit a bid on the championship for the following year no later than thirty (30) days after the current championship has been completed.
2. From thirty (30) to sixty (60) days after the current championship, bids will be accepted from the challenging sponsors. Each challenging sponsor may submit one bid.
3. At the close of the challenging bid period, the current sponsor will receive fifteen (15) days to top the highest bid by no less than five (5) percent.
4. In the event that a current sponsor does not submit a bid to re-sanction the title within thirty (30) days, the sanction will be granted to the highest bidder after the sixty (60) day period is over. If no bid has been received by then, the sanction will go to the first bidder that meets the minimum requirements.
5. All bids must be sent to the Chairman or his designated appointee by registered mail and must be postmarked no later than the deadline.
6. All bids will include the guaranteed total cash prize structure, the style, the dates and the Title.
7. After any sanction with a prize structure of \$5,000.00 or more has been granted, the sponsor must enter into a contract with the W.F.D.A. This contract guarantees prize money on the scheduled dates. The sponsor may cancel a sanction no later than ninety (90) days prior to the scheduled Championship in writing, without recourse. Sanction Fees aren't refundable.

### **D. CONTESTANT REQUIREMENTS**

1. A contestant may enter a modified gun division at a contest and may also enter the Hollywood Gunfighter division of the contest if allowed by the Host. Males only in Men's Division, Women may compete in the Men's Division when necessary. . She will not receive a place in the women's division

2. Western appearance is mandatory. Western appearance means western boots or moccasins, western style shirt, western style pants. Hats are optional. The only exception shall be temporary medical impairment, which must be approved before a contest by the head official.....Ball caps and bandannas will not be considered western wear!! No bare mid-rift shirts will be allowed while shooting. (Safety)
3. It is the responsibility of each contestant to be available when called to the firing line. A minimum of four (4) names shall be announced after each contestant leaves the firing line, to alert contestants of their competition order. Failure to report to the firing line within four (4) minutes of being called to the firing line will result in disqualification from that event or elimination round.
4. Contestants shall conduct themselves in a sportsmanlike manner and shall not disrupt or delay the contest. Penalty: Contest disqualification.
5. Contestants who arrive at a contest after the last shot of the first event has been fired, may still enter the contest, but must take the maximum score for the first event or an X for the first elimination round.
6. Contestants, who are present at a contest prior to its commencement and do not enter, will not be allowed to participate in any part of the contest once the first shot is fired.
7. At the discretion and consent of the W.F.D.A. officer sanctioning the contest, a physically handicapped member may compete.
8. A \$25.00 fine will be levied against any contestant for arguing with or abusing an official who is carrying out his/her duties. If a contestant continues to argue with or abuse an official, the official is authorized to bar that person from further participation in that contest. All fines must be paid to the W.F.D.A. prior to participation in further sanctioned contests.
9. All shooters, line judges, and backups, must wear protective eyeglasses for all W.F.D.A. sanctioned events.
10. Earplugs are recommended at all times.
11. Earplugs are mandatory for blank events.

## **E. SAFETY RULES**

Safety Rules are the most important rules we have in the sport of Fast Draw. Every member of the W.F.D.A. must read and fully understand these Safety Rules.

1. The Penalty for breaking the following Rules is **DISQUALIFICATION FROM THE CONTEST.**
  - a. Consuming or being under the influence of alcohol or drugs at any time before or during a contest.
  - b. Carrying an un-holstered or uncased gun outside the shooting area unless in a mandatory dry-fire area that has been previously established, except for the purpose of making adjustments, repairs or cleaning.

- c. Possession of any live ammunition in the contest area.
  - d. Pointing a gun at another person under any circumstances.
  - e. Use of fancy or unsafe gun handling at any time, unless as a demonstration requested by the host.
  - f. Discharging a gun while not on the firing line.
  - g. Disturbing the officials at the score table.
  - h. Turning or walking off the firing line with the gun in hand.
  - i. Looking down the gun barrel while on the firing line.
  - j. Loading or unloading a gun anywhere but on the firing line.
    - a. This does not apply to loading wax (only) into cylinders.
2. The Penalty for breaking the following Rules is grounds for **DISQUALIFICATION FROM THE EVENT OR ELIMINATION ROUND.**
- a. Failing to load and unload with the barrel pointed down range.
    - 1. Downrange is defined as pointing the barrel of the gun downward and towards the backstop and targets.
  - b. Failing to holster the gun while another person is down range.
  - c. Failing to show an official an empty gun prior to leaving the line.
3. Anyone within the shooting area must wear eye protection. Ear protection must also be worn if present during a blank event; this includes line judges, hand judges, contestant backups and photographers.

## **F. ANNUAL AWARDS**

1. World Top Gun Awards, with first place Men's and Women's title to be "All-Around World Champion".
  - a. A competitor will earn one (1) point for each contest entered and one (1) point for each contestant who places lower in the overall standings at each Chairman sanctioned contest.
  - b. There shall be a minimum of three (3) Chairman sanctioned contests each calendar year to qualify for World Top Gun Awards. Points from Open and Traditional Styles will be tallied together.
  - c. Awards shall be presented to top fifteen (15) Men and top eight (8) Women.
  - d. The Secretary shall have all records ready for the Chairman so that awards may be purchased and given out to winners no later than the first quarter of the year following the winning year.

- e. Each new record breaker (at Chairman sanctioned events only) are to be recognized with an award OR parchment designating his/her achievements.
  - f. In case of any ties, the contestant with the most contests won during the course of the season will win the tiebreaker. If this results in a tie their place finishes will be compared until the tie is broken. Example; Shooter #1 has one (1) 1st place and one (1) 2nd place, Shooter #2 has two (2) 1st places: Shooter #2 wins the tie breaker. This system will also be used to break ties for Area Awards.
2. There may be one (1) contest per year with the title of “All-Around World Championship”, which will replace the Top Gun Awards for that year.
- a. It must be sanctioned no later than June 1<sup>st</sup> and be held no sooner than September 15<sup>th</sup> of that year.
  - b. It must have a minimum of \$10,000 cash prize structure.
  - c. It must be by slotted invitation only.
    - 1. Slots are earned by placing in the top twenty-five (25) percent in any Chairman Sanctioned contest or class during the year.
    - 2. Slots are awarded to the Top fifteen (15) Men and Top eight (8) Women from the prior year.
    - 3. All-Around World Champions receive a two (2) year exemption, otherwise must qualify as in (1) and (2) above.
    - 4. The Chairman will be granted up to eight (8) slots to disperse as necessary for international competitors or other special considerations.
    - 5. Slots are also earned by a system of activity credits “Mission Count” for each area.
      - a. Each area will receive one (1) “Mission Count” for each competitor who competes at each sanctioned contest during the year. The Vice Chairman of each area will keep track of the “Mission Count” on a fiscal period from June 1<sup>st</sup> to May 30<sup>th</sup>. At that time the Chairman will announce how many slots will be awarded to each area based on their “Mission Count”. These slots will be awarded according to Area Top Gun Points.

The Vice Chairman may roll slots down to other competitors by order of finish of members in their area have earned slots through other means or can't attend the Championship.

6. Upon receiving the date, sanction fee, and the contract for the \$10,000 prize structure, the Chairman may sanction the contest.
  - a. By June 15<sup>th</sup> the Chairman shall appoint a "Championship Committee", consisting of three (3) Vice Chairman and the Host of the Contest. It will be the responsibility of this committee to choose a committee head between them. Their duties will be as follows:
    1. To pick the events to be held at the Championship.
      - a. The events should represent, in proportion, the most popular events being held at major contests.
      - b. The events should be chosen by taking in to consideration time allotted and available contest area.
      - c. Elimination and Index may be mixed in this contest by using inverted
      - d. There shall be one (1) event picked to be used as a tiebreaker.
    2. To establish the prize structure.
    3. To aid the host in staffing the contest.
    4. To prepare a report of the above items, for approval by the Chairman, by no later than July 15<sup>th</sup>.
    5. This committee may meet at a contest or by telephone conference. If by telephone conference the committee head will be reimbursed the phone charges.
3. Area Top Gun Awards are to be awarded in each qualified area.
  - a. A competitor will earn one (1) point for each contest entered and one (1) point for each contestant who places lower in the overall standing at each Vice Chairman sanctioned contest.

- b. Points from Open and Traditional Styles will be tallied together and an area must have a minimum of three (3) sanctioned contests to qualify for Area Top Gun Awards.
- c. One (1) award shall be present for every ten (10) members in that area, with a maximum of two (2).
- d. W.F.D.A. members from other areas may compete for year end awards and will be counted towards an area's one (1) award per ten (10) shooter ratio providing that they compete in at least fifty (50) percent of that area's Vice Chairman sanctioned contests.

## **. RECORDS**

- 1. World Records can only be established at Chairman sanctioned contests..
- 2. The Secretary shall maintain a World Record list and verify all new records with official score sheets.
- 3. All new single-shot or one multiple shot records must be backed up within .030 of a second during that Index event or Elimination round. A bye in elimination is considered a round. Three more attempts while still on the firing line will be allowed to establish it as a record. If the record shot or shots are not backed up as outlined above, it will be considered an act of anticipation and will result in the loss of the shot or shots. Shots fired only for the purpose of backing up a record will not be used as records or for scoring a contest.
- 4. If a record is tied it must be also backed up as prescribed in the previous paragraph; the contestant will be listed as a co-holder.
- 5. A separate set of World Records will be kept for Index, Elimination, Open and Traditional (Men & Women) events.
- 6. Records will be kept for the fastest single shot or one draw multiple shots, five (5) shot event totals and three (3) sets of doubles event totals.
- 7. Shots used to determine an average or to back up a new record will not qualify for World Records.
- 8. Vice Chairman contests that don't meet minimum record requirements will not use World Records to determine anticipation. It will be solely up to the judge to determine anticipation.
- 9. Membership is to be required to be recognized as a World Record Holder at the time the record was established. The score card must be sent to the Secretary.
- 10. Silhouette and Standard Rectangle do not require separate records.

11. Step-Back and Step-Up Events do not require separate records.

### **PART III EQUIPMENT REQUIREMENTS**

#### **A. GENERAL**

Any new products to be used in the sport of Fast Draw must be approved by the Executive Officers before using said product in competition. All holsters and manufacturers MUST have all "New" OR "Modified" holsters approved by the Executive Officers before selling to any individual knowingly using for W.F.D.A. competition. .

#### **B. GUN**

1. Single action revolvers Western Style only may be used. No caliber smaller than a .32 (.312) or larger than a .45 (.450) may be used. It must be a six shooter and can only be black, blue, chrome, or steel in color.
  - a. An official and approved gauge will be used to inspect the caliber of the barrel. If the barrel is deemed to be smaller than .312 or larger than .450 it will be considered illegal and must not be use in competition. (See Illustration "C")
2. The barrel shall be no shorter than 4 5/8" and must be a rifled barrel.
  - a. An official and approved gauge will be used to inspect the length of the barrel. The gauge will be set against the cylinder and along the barrel. If the barrel is not even with or above the sight line located on the gauge it will be deemed illegal and must not be used in competition. (See Illustration "E")
3. The trigger guard may be cut down, but not through. The trigger and/or trigger shoe may not extend beyond the edge of the trigger guard on the side of use.
4. Cylinder slots may be deepened but not cut through.
5. The hammer may not stick up or out more than 1/2" from the rear center of the top strap. (See Illustrations "A" and "B" ).
6. The hammer must hold on full and half cock when the gun is reasonably jarred. An exception will be the New Model Ruger or other single action revolvers, which feature safety devices on their original construction.
7. All parts must be installed and functioning. Sights are optional.
8. The new Ruger may be modified to work the same as the old model Ruger, with the same requirements as the old model.

9. The W.F.D.A. does not encourage the use of aluminum barrels or cylinders.
10. Single action revolvers used in the Hollywood division must be stock with original or duplicate of original parts. Action tuning and deepening lock slots for reliability is allowed.

### **C. HOLSTER-OPEN STYLE**

1. The holster must cover the entire barrel where it enters the frame, and fifty (50) percent of the cylinder, with the gun located in a shooting position when viewed from the side. (This shall be judged while contestant is standing in a normal, upright position).
  - a. A gauge with an indicator will be placed on the front of the boot and will be pushed in directly over the front lip. If the point of the indicator comes in contact with the gun barrel, the boot will be deemed illegal and must not be used in competition. (See Illustration "F")
2. It may not be a swivel holster or break open in any manner.
3. The gun and holster must be positioned so that the contestant can not shoot through the bottom of the holster and hit a target. Penalty: Loss of shot.
4. It must be western style and open at the top and bottom. The top of the belt may be no lower than four (4) inches below the top of the contestant's hip bone nor the bottom of the belt be higher than four (4) inches above the contestant's hip bone. The top of the holster boot may not be below the contestant's fingertips while in a normal standing position. Penalty: Loss of shot.
5. The inside opening at the top of the boot, including liner, may not exceed 2 ¾" width and 4 3/8" length (See Illustration "G"). The inside of the boot at its lip may not exceed 3 ½" from the closest part of the contestant's body.
6. A deflector shield may not slant towards the target or opponent in the shooting stance. Wheel Chair competitors must use a leather or metal leg shield.

### **D. HOLSTER-TRADITIONAL STYLE**

1. The holster must cover the entire barrel where it enters the frame, and fifty (50) percent of the cylinder, with the gun located in a shooting position when viewed from the side. (This shall be judged while contestant is standing in a normal, upright position).

- a. A gauge with an indicator will be placed on the front of the boot and will be pushed in directly over the front lip. If the point of the indicator comes in contact with the gun barrel, the boot will be deemed illegal and must not be used in competition. (See Illustration "F").
2. It may not be a swivel holster or break open in any manner.
3. The gun and holster shall not slant more than thirty-five (35) degrees from a vertical plane while in a shooting stance. Penalty: Loss of shot..
4. It must be western style and open at the top and bottom. The top of the belt may be no lower than four (4) inches below the top of the contestant's hip bone nor the bottom of the belt be higher than four (4) inches above the contestant's hip bone. The top of the holster boot may not be below the contestant's fingertips while in a normal standing position. Penalty: Loss of shot.
  - a. For Wheel Chair Competitors, the inside opening at the top of the boot must be within four (4) inches of the centerline of the body torso while seated in the wheel chair. (Note: This holster position only applies to Traditional Style). A leather or metal leg shield must be worn by a wheel chair competitor.
5. The holster must fit the gun. No "bucket boots" or "speed boots" are permitted. The inside opening at the top of the boot, including liner, may not exceed 2" width and 3" length for medium framed guns (Colts and Old Model Rugers Etc.) The inside opening at the top of the boot including liner, may not exceed 1 ¾" width and 2 ¾" length for small framed guns (.22/.38 etc.). The inside of the boot at its lip shall not exceed 3 ½" from the closest part of the contestant's body. If a contestant is using a "New Model Ruger" or another similar large framed pistol the boot width can be no more than 2 ¼". (See Illustration "G") Note all traditional holsters will be measured as illustrated in "Illustration G", the lengths and widths specified above must be substituted for those in the illustration.
6. The holster must be fastened to the leg with a tie-down strap. The bottom of the holster must be positioned against the leg. (No spacers).
7. The holster belt must be western style and straight, no dropped belts.
8. The deflector shield may not slant towards the target or opponent while in the shooting stance.

## **E. TARGET AND TIMING EQUIPMENT**

1. Wax Targets
  - a. Standard Silhouette shall be 30 ½" high by 14 ½" wide in the body and 8" by 8" for the head. The top of the head shall be 6'

from the ground. It shall be black with a 1' white border around the perimeter. The opening for viewing the signal light shall be a minimum of 3".

- b. Standard Rectangle shall be 30 ½" high by 14 ½" wide. The top of the target shall be 64" from the ground. It shall be black with a 1" white border around the perimeter. The opening for viewing the signal light shall be a minimum of 3". Note: All records shall be combined for the Standard Silhouette & Standard Rectangle.
- c. The 9" impact target shall be a 9" diameter round plate with a 3" minimum signal light opening in the center of the target. The target shall be black with a 1" white border. It shall be mounted on a stand that will allow vertical placement.
- d. Blocker Rectangle Target shall be 40" high by 20" wide. The corners of the target must be rounded using a three-inch radius. The top of the target shall be 64" from the ground. It shall be black and must be coated with white lithium grease. The opening for viewing signal light shall be a minimum of 3" in the center of the target. It can be used in either Index or Elimination events.
- e. The 9" Balloon may also be used as a wax target at 12'.
- f. The Balloon-Disc target shall be 17 5/16" diameter round concave plate, with a balloon hole in the middle and a 3" signal light opening centered in the upper portion of the target. The target shall be black with up to a ½" white border. The concept is that a hit anywhere on the target is sufficient to break the balloon in the center, for a visual effect. The concave should be substantial enough to break the balloon with a high percentage. The balloon is only considered a hit indicator and shall not be required to break, if the Balloon Disc target is hit. There shall be a back plate behind the balloon, which is also capable of stopping the timer. (See Illustration K) The center of the target is to be set at 44" above the ground.
- g. Standard Plate shall be 17 5/16" in diameter. The center of the target will be set at 44" above the ground. It shall be black with a ½" white border. The opening for viewing the signal light will be centered and a minimum of 3". Note: All records shall be combined for the Balloon-Disc and Standard Plate.
- h. A coating of White Lithium Grease may be used on any wax target (except Balloon-Disc). **If it is used then the white border shall be eliminated.**

I All wax targets will be calibrated as to stop with a .45 caliber wax bullet at 15' with only a pistol primer and not to go off on sound with a .22 blank with out wax at 5'.

1. If a target does not stop and a full/bullet hit is not verified by target judge, then the contestant has the right to call for a calibration check. The official will fire a 045 caliber wax bullet with a pistol primer at whatever distance that the shot in question occurred. If the timer stops the contestant will be scored a miss; if the timer does not stop the contestant will receive a re-shoot.

2. Balloon Targets 4" and 9"

- a. The balloon holder shall be constructed so that a part of the balloon extends forward of the target holder surface, but shall not allow a balloon diameter greater than 4" or 9" respectively. The light shall be mounted above the balloon such that the center of the light shall not be further than 6" above the edge of the balloon. The opening for viewing the signal light shall be a minimum of 3". The balloon holder shall be mounted on a stand that will allow vertical placement.
- b. The center of the balloon shall not be placed lower than the center of a contestant's gun belt buckle while standing in a normal upright position. The contestant will walk up to the balloon stand to adjust the height accordingly.

Penalty: Loss of shot.

3. A mobile stand for walking events may be used to keep the target at a constant distance from the shooter. The handle for the cart operator must always be a minimum of 3' behind the shooting distance. Provide the vertical placement, as required.
4. Any target signal light bulb shall be clear or amber and a minimum of 60 watts at 110V AC. The bulb shall be a minimum of 2" in diameter and should be protected in front by a clear shield. The bulb shall be shielded above, back and sides from direct sunlight using a "WHITE" colored interior coating.
5. In Index contest only, sound (S), or micro-switch (M) pick-ups in the balloon events may be used. If sound pick-ups were used it must be indicated with (S) in the contest results.
  - a. If micro-switches are used with multiple targets in Index contests they must be calibrated.  
(See part IV B. Scoring Elimination-e)

6. All wax events shall have a backboard of a material that will stop wax bullets. (See Site Preparation, Part V, Section B).
- 7.
7. The electronic timer shall have as a minimum the following:
  - a. Digital readout(s).
  - b. 2-5 second random start.
  - c. Dual channel input with the capability to read both channels.
  - d. It must be made to function on micro-switch or sound inputs.
  - e. Voltage supplied to the target light(s) shall be alternating current and not less than 90 volts R.M.S.
  - f. It must function properly on a minimum of 90 volts line voltage.
  - g. The timer must allow no more than .020 second delay from the time the target light is turned on until the timing sequence begins..
8. All electronic sensors installed on wax targets used in any given contest must be of the same manufacturer and part number.

## **F. AMMUNITION**

1. Blank Loads
  - a. Only commercially purchased rifle, pistol, shotgun and black powders can be used.
  - b. Maximum wad thickness is 1/16" including glue and sealer.
  - c. No brass shall be used that is cracked or split.
  - d. No shell casings of larger caliber or greater than a .45 Long Colt.
  - e. Blank loads can be furnished by Host if advertised in advance.
  - f. All Walk and Draw Level loads must be tested prior to practice.
  - g. Commercially loaded blanks are allowed.
2. Wax Loads
  - a. Only commercially manufactured wax bullets shall be allowed currently Red Jets, Excaliber, Searls, Super Speed, C&R, and Super Speed have been approved. Bullets may not be altered in a way to cause them to split.

- b. Wax bullets shall be propelled by only factory made pistol primers, shotgun primers, or 22 short black powder blanks.
  - c.
3. If a misfire occurs on any host supplied ammunition a designated test gun will be used to fire the round. If the round does not Any W.F.D.A. approved wax may be loaded with no more than 6 grains of 4 F black powder or black powder substitute. Supplied by the "**HOST**". This must be advertised in the contest advertisement at least 30 days in advance. (This was effective May 5th, 2001 as a **SAFETY RULE**.) fire in the test gun, then a re-shoot will be granted. The test gun will be designated by the host before commencement of the contest.

## **PART IV COMPETITION RULES**

### **A. GENERAL**

1. Prior to receiving the signal to draw, the contestant's hands shall be placed in the following manner, **LAWMAN READY POSITION**.
  - a. The trigger finger shall not enter the trigger guard.
  - b. After the command has been given, the contestant shall not be falling back and become off balance, if it is obvious to the officials the he/she is using this method consistently to anticipate the light he will be first and then the second time will be a loss of shot..
  - c. Prior to shooting and setting gun in holster and the signal "Ready Set command" given, the hammer must be in the fully down position to begin the draw.
2. Contact with the gun caused by a flinch due to a sudden, loud noise or other disturbance, the contestant will receive a re-shoot. The contest officials in the immediate area shall have sole authority, by a majority vote, to grant a re-shoot.
3. Any attempt to draw and fire on a light, whether it is a quick or slow light, will be considered a legal draw. Only the Line Official may determine if a disturbing flash of light occurred, in which case, the contestant would receive a re-shoot. The Line Official's decision is final.
4. Once the "shooter set" command has been given there will be no call off allowed by any competitor
5. The ready command may be given by either the contestant or clock operator. If the clock operator gives the signal, it shall be stated as "Shooter on the line, shooter set". In walking events, the shooter may walk when ready or take a command from the clock operator in which case it shall be stated as "Shooter on the line, shooter walk".

6. After the command is given, the random signal to draw shall not come on before two (2), nor later than five (5) seconds. In walking events
7. (moving target) the contestant will be given two (2) steps before random count begins.
8. In all standing events, the competitor's gun, holster and feet must be behind the shooting line. Note: If a piece of tape is used as a line, both feet must be behind the edge closest to the shooter. In walking events, the gun is used to establish shooter's position. (Exception: Competitors in wheel chairs may line up with the holstered gun behind the line).
9. No shooter may have more than one (1) back-up helper on the line at any time. Penalty: Loss of shot.
10. PROTESTS: All protests from contestants must be made immediately at the time the violation occurs. At no time will the protest be considered valid unless it is made before the contestant fires the next shot. A shooter that makes an off-the-line protest will be required to put up a \$20.00 protest fee. If the protest committee upholds the protest, the fee will be returned to the shooter making the protest. If the protest is not upheld the \$20.00 fee will go to the W.F.D.A. treasury.
11. Any contestant at a WFDA sanctioned competition may be allowed to be given the name of his/her accuser in the event of his/her being accused of breaking a WFDA rule, as well as being informed of the rule number or numbers, immediately after such allegations are made if he/she requests such.
12. It is the shooter's right to protest a call an official has made, it must be done immediately at the time and not after the next shot is fired or after they leave the line. A supervising official may overrule the call if it has to do with enforcement policy and settle the matter.
13. An "Arbitration Committee" will be formed to handle any unsettled protests.
  - a. . The host will pick three experienced members to form the committee. At a Vice-Chairman Sanctioned contest the Vice-Chairman will act as Mediator, at Chairman Sanctioned contests the **Chairman** will act as **Mediator**. The immediate contest officials are barred from this committee. The competitor, officials, and all arbitration committee members shall be present during all testimony.
  - b. The mediator will first call to witness the official or official's who made the call or the protesting contestant (if other than shooter on the line) to explain what they saw. Then the contestant (shooter on the line) will explain their position. At this time any other witnesses that may have relevant information to the case may be heard. Then the officials or protesting contestant will have one more turn, then the contestant (shooter on the line) will have the final comment.
  - c. Committee members will refrain from expressing any opinion or verdict upon a dispute in progress.

- d. When the committee is satisfied that they are in possession of all information and evidence relevant to the dispute, they will deliberate privately. The Mediator will explain to the committee all pertinent rules and enforcement policies relevant to the case. The committee will reach their decision by majority vote.
  - e. After the committee has made the ruling the Mediator will summon the compliant, the official(s), and the Host and the committee will then deliver its judgment.
  - f. It is the responsibility of the Host to implement the decision.
  - g. The decision of the Arbitration Committee shall be final and may not be protested, unless in the opinion of the Host or Mediator, new evidence forthcoming warrants reconsideration.
12. On targets where White Lithium Grease is used, only the Hand Judge and Line Judge may approach the target to confirm a hit or miss.

## **B. SCORING**

1. **INDEX** : Index events are those in which each shot is recorded and all recorded scores are totaled to determine the overall winner. No other method of determining an overall winner may be used. One contestant or more will shoot at a time: if more than one (Elimination Style), it must be advertised in the "TOP GUN) magazine.
  - a. Ties in overall scores for which prizes are to be awarded shall be broken by each tied contestant re-shooting three shots of the last event in the contest. A second tie shall be broken by re-shooting one shot of the last event in that contest. If one of the tied contestants is ineligible or not present to break a tie, that contestant automatically forfeits the shoot-off. If neither contestant is eligible or present to break a tie, the tie shall be broken by the fastest shot that each contestant fired in that contest.
  - b. Official or approved W.F.D.A. score sheets must be used.
  - c. All scores shall be recorded in thousandths of a second.
  - d. A score of 1.000, or one second, shall be given for missed shots, except doubles.
  - e. Recorded scores will be totaled, then immediately re-totaled by a different scorekeeper.
  - f. More than one shot per draw, except doubles, is not allowed. Penalty: Loss of shot.
  - g. Any host shall be given the option to use the "Inverted Score Shooting Order". The purpose of this system is to make the end of the contest more exciting for both the shooters and spectators. It is done by adding all scores prior to the last event. The contestants are then numbered for shooting for shooting order in the last event by their standings in the prior events. Thus, the contestant who is last in the standings shall shot first. A list of shooting order must be posted prior to

- starting the event. **however, if a contest is run Elimination Style (index scoring), inverted scoring MUST be shot in the same manner with Championship final rounds being elimination style also.**
- h. **Style (index scoring), inverted scoring MUST be shot in the same manner with Championship final rounds being elimination style also.**
  - i. **In any two or three day contest the shooting order may not be reversed.**
  - j. There will be no classification in Index contests.
  - k. If the timing equipment malfunctions and the target is hit, the contestant may either:
    1. Take the shot over and receive that time, hit or miss.
    2. Take an average of all clean hits in that event except recovery shots (shots fired after the first attempt to fire fails).
      - a. If a contestant fails to register a clean hit for averaging purposes, three (3) more attempts will be allowed to secure a clean hit. If a clean hit is not accomplished during the three (3) additional attempts, the shot in question will be declared a miss. Only one such hit is sufficient for an average. A contestant shooting for an average shall use the same style used in that event.
      - b. In Step Back or Step Up Wax event, an average must be secured at whatever distance the malfunction occurs. Example: Malfunction at 10', the contestant must return to that distance to secure a (clean hit), after completion of the entire event.
    3. Timing equipment malfunctions on a recovery shot can either be re-shot as follows: Only one round allowed in cylinder, to be indexed such that two definite strokes of the hammer will only fire one round, on the second stroke. Penalty for a miss 1.000 sec., or take an average of all clean hits in that round and add .200 sec. to that score for recovery shot in question.
- 2 ELIMINATION: Elimination events are those in which two competitors receive the signal light at the same time, the fastest hit winning.
- a. Elimination may be either single, double elimination, etc., i.e., a contestant is defeated once, twice, or more before being eliminated from an event.
  - b. A round winner will be determined by the best two (2) out of three (3) or best three (3) out of (5) shots.
  - c. Contestants shall stand on the same line facing the same direction with a minimum of 8' separating the targets. In lieu of this requirement, a protective barrier may separate the contestants and targets.

- d. All elimination shall be one shot per target per draw.
- e. Micro-switches must be used in all blank Elimination events. The micro-switches must be calibrated as follows:
  - 1. Place the balloon stands close enough together so that one blank will break both balloons.
  - 2. Fire a blank round to break both balloons simultaneously. Both channels of the timer must read identical times at least three consecutive times before calibration is complete.
- f. Scores read from the dual channel timer shall be used to determine the winner of a shot. All scores, including lost shots, shall be recorded on an official W.F.D.A. Elimination score sheet.
- g. Tied scores must be re-shot.
  - 1. If a time cannot be read from both channels, the shot must be taken over, providing both contestants hit the target.
  - 2. If a time cannot be read from both channels, after both contestants shoot and only one hits the target, the contestant with the hit wins the shot with a No-Time.
- h. The time limit for elimination shall be whatever the miss penalty would be for that event in an Index contest. Any shot or shots fired after the time limit, shall be declared a miss.
- i. In elimination contests with more than one event the overall results will be determined on the basis of inverted points. Each contestant receives one point for entering each event plus one point for each opponent defeated. A contestant wins one point for winning the bye. Determine overall standings by adding points earned in each event.
- j. Pairing of contestants shall be by random draw only. If an odd number of contestants remain in the contest, pairs will be drawn until three (3) names are left. The fastest single shot within his or her class (classification times) receives the bye.
  - 1. (Host's Option) Contestants in Elimination contests will be matched up in rounds according to the number of X's in that contest. Winners will be matched with winners and losers will be matched with losers, from the previous round. All remaining rounds will be randomly drawn.  
Example: In a 3X contest, there will be a container for winners and a container for losers in each class, In the 2<sup>nd</sup> and 3<sup>rd</sup> rounds, the matches will be drawn from separate containers filled from the prior round. The 4<sup>th</sup> and following rounds will all be mixed together and randomly drawn.
- k. Ties in overall standings, for which there are prizes or awards, shall be broken by running a single elimination event.

The tie-breaking event may be picked by the host from among those events in the contest, and must be previously advertised. A bye winner in a tie-breaking shoot-off automatically wins the highest place of those tied. Ties in overall standings, for which there are no prizes or awards, shall be broken by the fastest shot fired by the tied contestants in that contest.

1. Single shot standing balloon elimination cannot be shot as unclassified elimination unless two (2) or more events are in the contest. Double balloons may be shot as unclassified. However, both targets must be hit to get a time. If only one target is hit, >>No Time!
- m. Contestants who jump the light (anticipation) will lose that shot to their opponent with "No-Time", regardless.
3. Index and Elimination events shall not be mixed in any contest except the All-Around World Championship and Progressive Eliminator.
  - a. Progressive Elimination may be used as an alternate method to determine final overall placement.
    1. The host shall determine in advance how many places will qualify.
    2. It may be single or multiple X.
4. Scores will be posted at all Chairman and Vice-Chairman sanctioned contests, as each contestant finishes each event, in a manner and size large enough to be read by contestants and spectators.
  - a. The posting board shall be stationed well away from both the shooting area and score keeping area.
  - b. Posted scores are not official scores.
5. Classification for Elimination contests:
  - a. S/B 4" @ 8', S/B 4" @ 10', S/B 9" @ 12', S/W @ 8', S/W @ 10' (Open Style).
    1. There shall be four (4) classes in the Men's Division and three (3) classes in the Women's Division. Men's C and Women's B are at Host Option.
    2. Men's Division
 

AA	.000	to	.259
A	.260	to	.299
B	.300	to	.379
Optional.	C	.380	and up.
    3. Women's Division
 

AA	.000	to	.319
A	.320	to	.379
Optional	B	.380	and up.
  - b. S/B 4" @ 8', S/B 4" @ 10', S/B 9" @ 12', S/W @ 8', S/W @ 10' (Traditional Style).
    1. There shall be three (3) classes in the Men's Division and three (3) classes in the Women's Division.
    2. Men's Division
 

AA	.000	to	.319
A	.320	to	.379
B	.380	and up.	

- |    |                  |    |              |
|----|------------------|----|--------------|
| 3. | Women's Division | AA | .000 to .359 |
|    |                  | A  | .360 to .459 |
|    |                  | B  | .460 and up  |
- d. This Elimination Classification system is to be used for events shown above only. An Elimination contest that has two (2) or more events will be shot as unclassified.
  - e. In all Elimination classifications system, any contestant can shoot in any class that they want and move up and down in classes, but not in the same contest.
  - f. If a contestant shoots out of class with a faster time it will be scored a miss. In order for the opponent to win the shot they must score a hit no faster than their class limits.
  - g. There will be a minimum of three (3) trophies awarded in each class.
  - h. In classified elimination the winners of Men's AA Class and Women's AA will be considered the Overall Champions of that contest
  - i. \*In classified elimination, winners of every classification will be considered World, National, or State Champion of his or her class.
6. SHOOT UNTIL HIT: Host may choose "Shoot Until Hit" format, advertised in advance.
    - a. On single target events the miss penalty will be two (2) seconds.
    - b. On double target events the miss penalty will be three (3) seconds.
    - c. The host must provide safe loading tables off of the firing line, which are surrounded on three sides by a backstop material capable of stopping a wax bullet.
      1. Competitors must leave the line to reload their weapons.
      2. Guns must be holstered while not on the firing line or away from the loading booth. Guns must be holstered before turning around to leave the loading booth.
      3. Contestants may load in the loading booth while in "the hole".
    - d. Shoot until hit can be run Index or Elimination.
    - e. In case of anticipation the shooter receives the miss penalty.
    - f. In double target events, the left target must be engaged first (if right handed), and opposite if left-handed. The contestant may re-engage the first target either before or after the second target is engaged.

### C. EVENTS

1. The events listed below are the only ones that may be used in a sanctioned contest and must be advertised in advance. Abbreviations are located to the right.

- a. Wax events: Standard Silhouette, Balloon-Disc, Standard Rectangle, Standard Plate, 9" Impact Target, \*9" Balloon Target and Blocker Target.
1. Standing Wax: 5', 8', 10', 12', and 15' S/W
  2. Step Back Wax: 5', 8', 10', 12', and 15' S/B/W
  3. Step Up Wax: 15', 12', 10', 8', and 5' S/UP/W
  4. Walking Wax: 15', moving target. W/W
  5. Walking Wax: 15' to 12', stationary target. W/W
  6. Walking Wax: 21' to 15', stationary target. W/W
  7. Double Wax: 12', targets 8' center to center. D/W
  8. Double Wax: 8', targets 6' center to center. D/W
  9. Standing Wax: 12', \* 9" balloon S/W

## The 9" balloon target may only be used as a wax target at a distance of 12'.

- b. Blank Events: 4" Balloon Target and 9" Balloon Target.
1. Standing Blanks, 4" balloons, at 8' and 10'. S/B
  2. Standing Blanks, 9" balloons at 12'. S/B
  3. Walking Blanks, 4" balloons, 12'-8', moving target. W/B
  4. Walking Blanks, 4" balloons, 12'-8', stationary target. W/B
  5. Double Blanks, 4" balloons, at 8', targets 6' center to center D/B
  6. Double Blanks, 9" balloons, at 12', targets 8' center to center D/B
  7. Step up balloons, 15', 12', 10', 8', 5' S/UP/B
  8. Step back balloons, 5', 8', 10', 12', 15' S/B/B
  9. Standing Blanks, 4" balloons 15' S/B
  10. Walk and Draw Level (Elimination Only). W/D/L
  11. If you can hold an event in a Vice Chairman contest, the same event can be held in a Chairman contest.

PLEASE NOTE: Double Balloon 4" at 8' Elimination ONLY voted on, NOT ALL events.

2. An event includes all shots fired at one type of target, at a specified distance, and with specified ammunition. The number of shots fired is immaterial in defining an event or round.
3. Walking events shall be conducted as follows:
  - a. Moving targets, the target shall be pushed at a rate which keeps it the specified distance from the shooter.
  - b. Stationary targets, the shooter shall start at a "toe line" three (3) feet beyond the furthest shooting position from the target.
  - c. The contestant must start a normal walk and continue at the same pace until the shot is fired. Penalty: First occurrence will result in a warning. Second violation will result in a loss

of that shot. Only one warning per event.

- d. After the walk and draw has started, the shooter may not touch the gun or any part of the rig before the signal light. Penalty: Loss of shot.
- 4. The following rules apply to all Blank Events.
  - a. The center of the balloon shall not be placed lower than the center of a contestant's gun belt buckle while standing in a normal upright position. The contestant will walk up to the balloon stand to adjust the height accordingly. Penalty: Loss of shot.
- 5. The following rules apply to the double target events:
  - a. The target centers will be placed at the specified distance, with the front center of a 14"X14" box placed at the specified shooting distance from each target. (See Illustration J).
  - b. The contestant's holstered gun must be within the 14"X 14" box as indicated above. Penalty: Loss of shot.
  - c. The penalty for a miss shall be a maximum of 1.000 per target. The total time shall be as follows.

<u>Number of Hits</u>	<u>Score</u>
Hit both targets	Time on second target
Hit first, missed second	Time on first + 1.000
Missed first, hit second	Time on second + 1.000

- d. The targets will be shot in order from left (first target) to right (second target) for a right-handed contestant and from right (first target) to left (second target) for a left-handed contestant.
- e. The penalty for firing more than two (2) shots in a double target event will be two (2) misses, unless it is designated a "shoot until hit" event.
- f. If a timing equipment malfunction occurs on hit targets, and no other similar scores are available to average, the following shall apply.

<u>First Target</u>	<u>Second Target</u>	<u>Ruling</u>
Target hit but timer malfunctioned	Target hit but timer malfunctioned	Shoot until both targets are hit again. (3 tries maximum)
Target missed	Target hit but Timer malfunctioned	Shoot until both targets are hit again. (3 tries maximum) Add 1.000 to second Score.

Target hit	Target missed	Shoot until both
Timer malfunctioned		targets are hit again.
		(3 tries maximum)
		Add 1.000 to first
		Target score.

6. A shooting line is the designated distance line for shooting each event, including DOUBLES.

#### **D. TRADITIONAL STYLE CONTESTS**

##### **POLICY PURPOSE:**

1. The essence of a Traditional Style contest is to preserve the Western appearance of Fast Draw while maintaining a high level of competition.
  - a. Thumbing, ram fanning, and slap cocking only. No twisting draws of any kind will be permitted before, during or after the draw..
2. At the Host's option, a Traditional contest may be Thumbing only. Vice-Chairman contest points shall not be counted toward year end points.

#### **E. TWISTING STYLE CONTESTS**

##### **POLICY PURPOSE:**

1. The essence of a Twisting contest is to preserve the historical evolution of the word Fast in Fast Draw.
  - a. Twist-fanning and Twist-thumbng only. No traditional draws will be allowed. There must be an obvious twist to the draw.
  - b. Any style of holster outlined in the Rulebook will be permitted.
2. At the option of the host, any contest may be Twisting only.

#### **F. OPEN STYLE CONTESTS**

##### **POLICY PURPOSE:**

1. The purpose of Open Style contests is to allow all styles of Fast Draw Shooters to compete against each other.
  - a. Twist fanning, up-fanning, ram-fanning, slap cocking, and thumbing styles may all be used.
  - b. Any style of holster outlined in the Rulebook will be permitted.

#### **G. TRADITIONAL OPEN STYLE CONTESTS**

##### **POLICY PURPOSE:**

To allow all styles of Fast Draw shooters to compete against each other.

- a. Twist fanning, up-fanning, ram-fanning, slap cocking and thumbing styles may all be used.
- b. Holsters must be a Traditional style holster as outlined in the WFDA Rulebook.
- c. Must comply with all WFDA Safety Rules.

## H. HOLLYWOOD DIVISION

### POLICY PURPOSE:

To allow new shooters or those that prefer not to shoot modified guns to use their stock single action guns in .45 Colt, 38/357 caliber and unmodified holsters to compete in fast draw. The rules for this type of contest are like the other rules other than the following:

1. Only **stock guns** may be used. Action jobs and deepening the lock slots on the cylinder are allowed. No aluminum or titanium substitute parts and no fanning hammers (except 2nd shot in doubles may be fanned).

2. Holsters can be any SASS, or CFDA legal holsters, but no twisting or bucket holster (This includes buscadero and steel lined holsters such as the Arvo Ojala, Andy Anderson, and Alfonso holsters). Deflector **shields** at the bottom of holsters are recommended for all, **required for blanks**.

3. Thumbing only, except doubles. A second shot may be fanned.

4. Shooter can start in the lawman ready position, i.e. hand on the gun with finger outside the trigger guard.

5. Standard wax target will be a standard silhouette or standard rectangle at 15 feet.

6. Blank targets will be at the same distances we use now; blanks can only travel so far.

7. The Hollywood division will shoot against other people in that Division, either as a separate contest or a separate Division if there is also a modified gun WFDA Division in the contest.

. Just as in our current contest types, Hollywood can be shot as an elimination contest or as an index contest. Elimination contests can be shot at Host Option as unclassified or classified with AA, A, and B cutoff times as in our modified gun minimum times.

## PART V HOST REQUIREMENTS

### A. HOST RESPONSIBILITIES

1. It is the Host's responsibility to run a contest sanctioned by the W.F.D.A. according to all Rules & By-Laws to the best of their ability.

It is the Host's duty to see that a contest is properly manned with the number of officials necessary to enforce the rules. The Host may request a list of Certified Range Officers from the W.F.D.A. in advance.

2. When possible, there must be a Certified Ranger present to supervise all Safety regulations ensuring that all rules are enforced at a Chairman Sanctioned contest. Does not mean the Certified Ranger must actually run the line at all times

## **B. SITE SELECTION**

1. The host shall select a site which:
  - a. Is flat and relatively smooth. For walking events, the walkway should be void of protuberances which might trip a contestant.
  - b. Can be surrounded by a barrier for safety (i.e., roped off, etc.)
  - c. Is protected if inclement weather is expected, if possible.

## **C. SITE PREPARATION**

1. The contest site should be oriented to prevent contestants from looking directly into the sun. The shooting area shall be prepared as follows:
  - a. The shooting area shall be surrounded by a barrier (roped off, etc.) which will prevent shooters or spectators from inadvertently wandering into the line of fire. Only one entrance will be established to the rear of the shooting area. No shooter or spectator shall be allowed downrange from the shooting line closer than eight (8) feet laterally to the backstop.
  - b. Backstops are mandatory at all sanctioned contests. Backstops are to run beyond the target at an intersection point of at least forty-five (45) degrees from the farthest shooting position. Backstops to be a minimum ninety (90) inches high and are to be constructed of 5/8" plywood minimum for wax events and 1/2" plywood for blank events. Targets to be a maximum of two (2) feet up-range from the backstop.  
**Exception:** When a contest is conducted at a "live ammo" shooting range, and if also the host, the sponsor and the WFDA Vice-Chairman for that area ALL agree that a back stop is not necessary for safety, then the requirement for a backstop is waived.
  - c. A large table and sufficient chairs shall be placed behind the shooting line preferably on the right for the clock operator and scorekeepers.
  - d. Every contest shall have a Line Official provided by the host.
  - e. The shooting line shall be distinctly marked on the ground surface

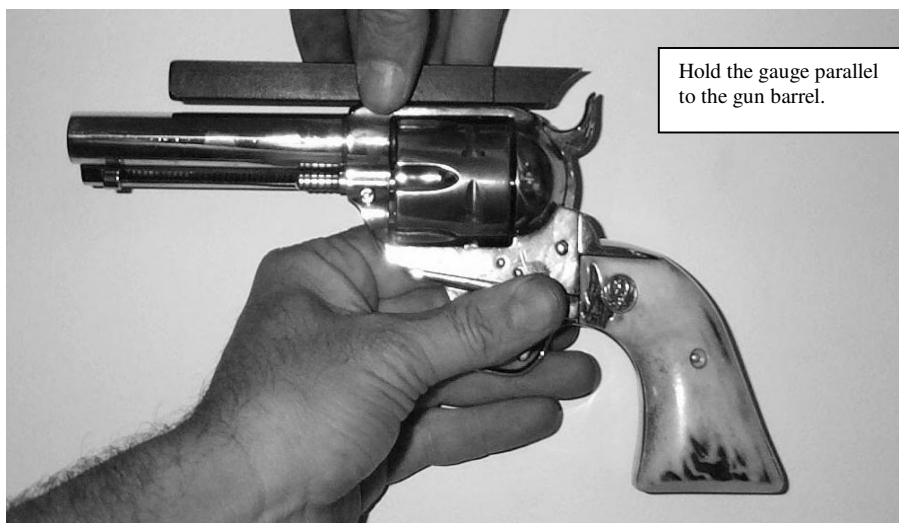
- f. Hosts of all sanctioned contests shall post the Safety Rules in a conspicuous place and conduct a safety meeting before the commencement of each day of shooting.
- g. If handicapped competitors are in attendance, suitable access to the shooting area and facilities should be provided. It is the handicapped contestant's responsibility to inform the Host of requirements in advance.

#### **D. DRY FIRE AREA**

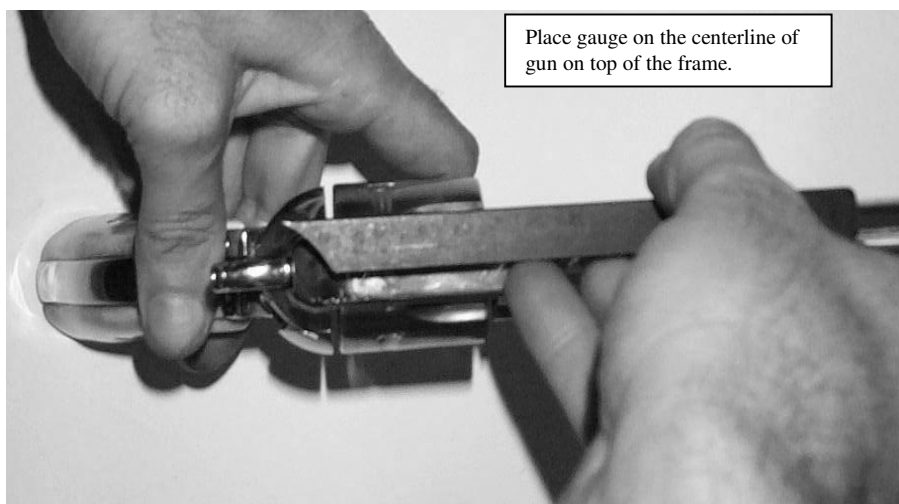
1. A dry fire area is mandatory and must meet the following minimum criteria:
  - a. It shall be no closer than seventy-five (75) feet from any shooting site, unless there is a suitable sound barrier.
  - b. It must be placed along a building or wall, solid fence, or other backstop, which would stop a wax bullet.
  - c. It must be surrounded by a barrier (roped off, etc.) to prevent shooters or spectators from wandering in front of practicing shooters.

## PART VI ILLUSTRATION SECTION

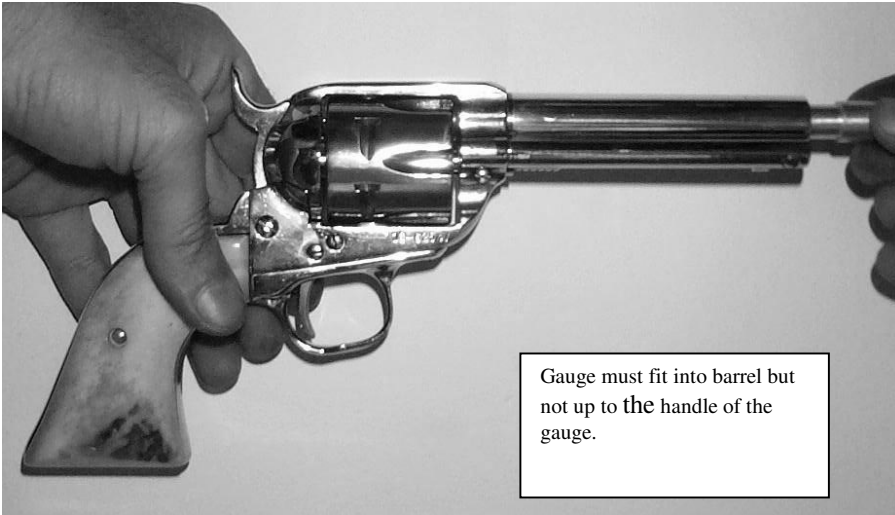
**Illustration "A" (Hammer Height)**



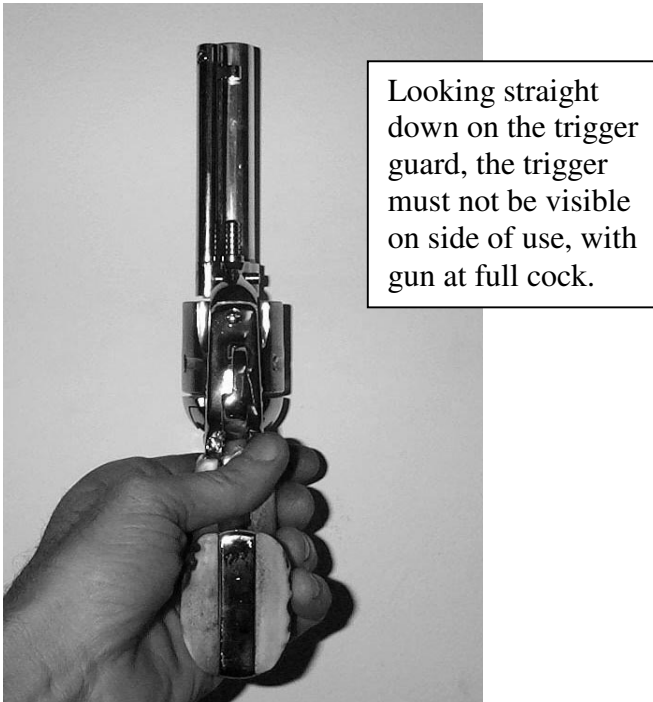
**Illustration "B" (Hammer Width)**



**Illustration "C" (Barrel Size)**

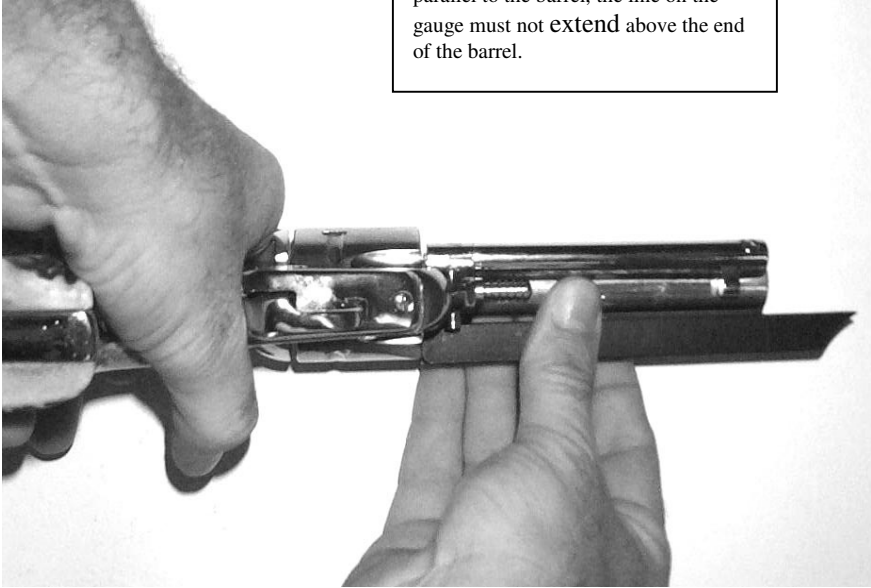


**Illustration "D" (Trigger Guard)**



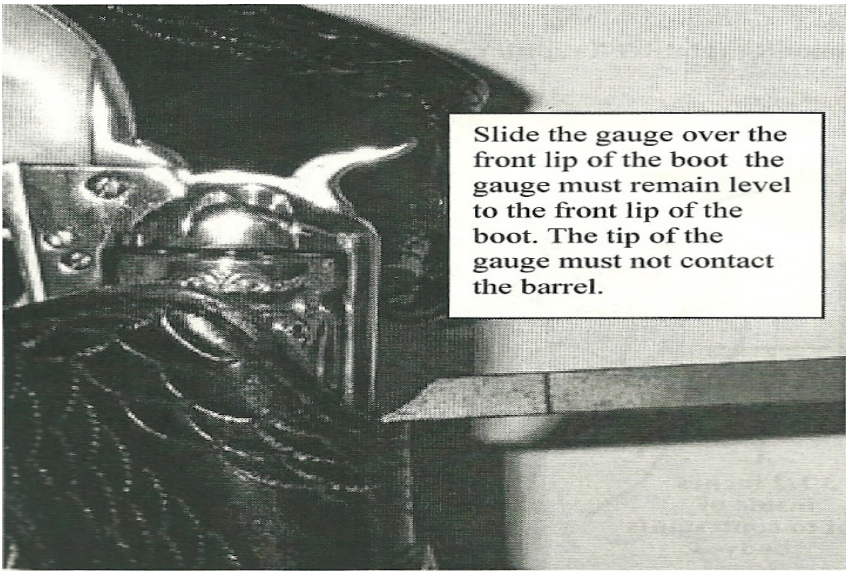
**Illustration "E" (Barrel Length)**

Place the gauge against the cylinder and parallel to the barrel, the line on the gauge must not extend above the end of the barrel.

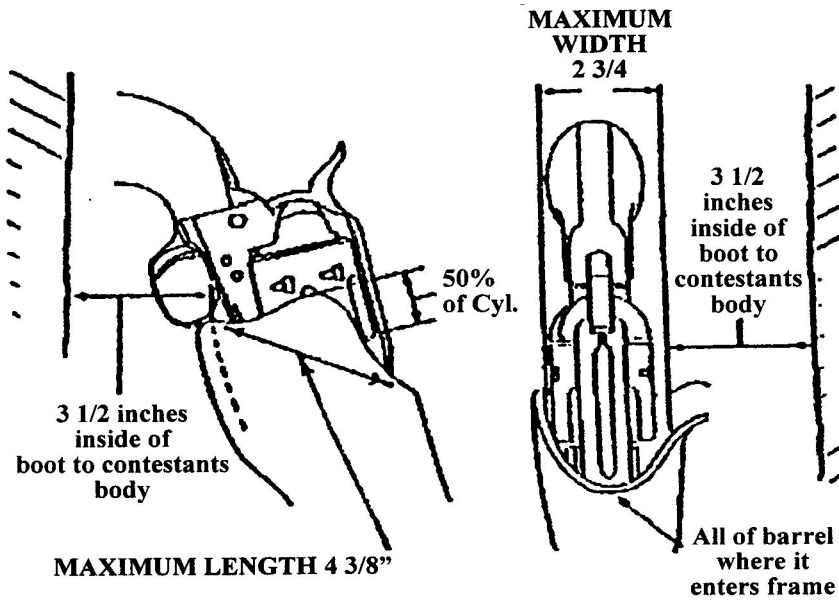


**Illustration "F" (Holster Gauge)**

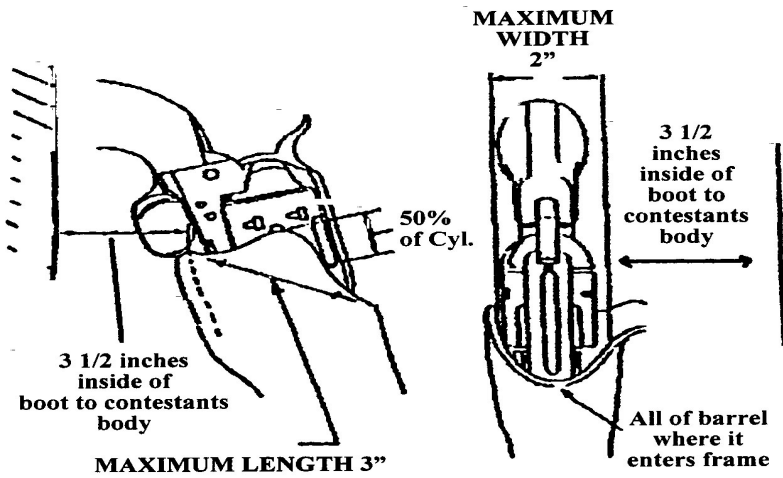
Slide the gauge over the front lip of the boot the gauge must remain level to the front lip of the boot. The tip of the gauge must not contact the barrel.



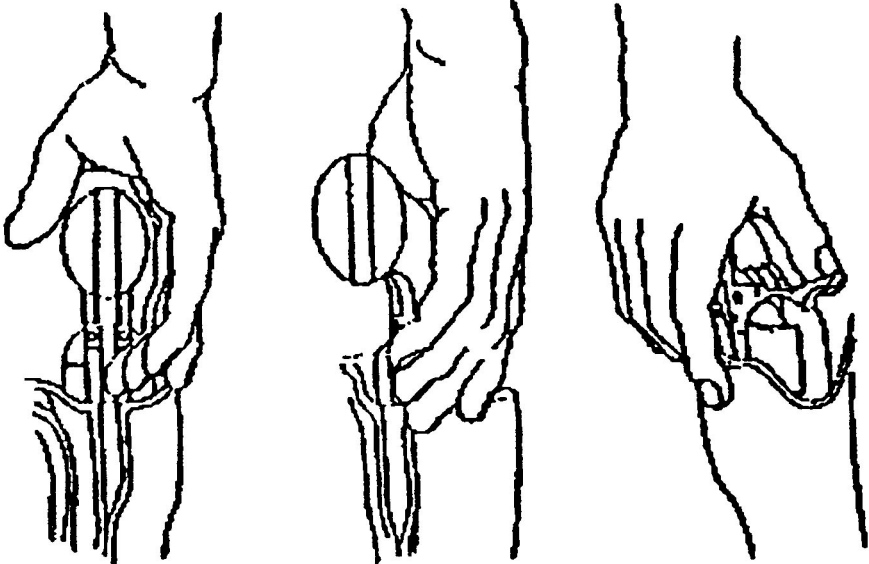
**Illustration "G" (Holster Open Style)**



**Illustration "H" (Holster Traditional Style-Medium Frame Gun Shown)**



**Illustration "I" Hand Clearance (When Required)**



**Illustration "J" (Double Target Layout)**

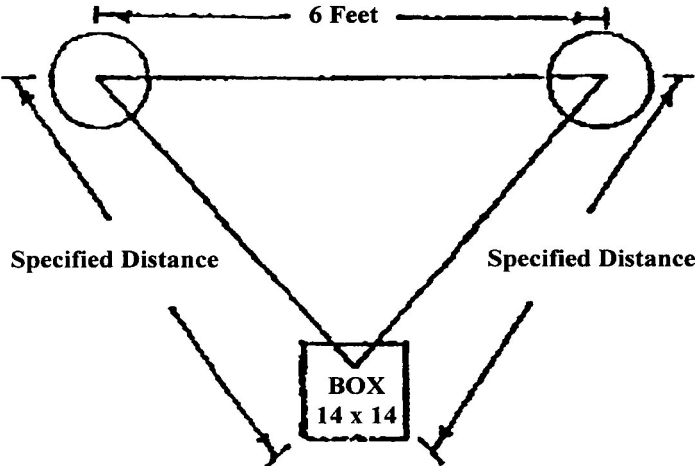
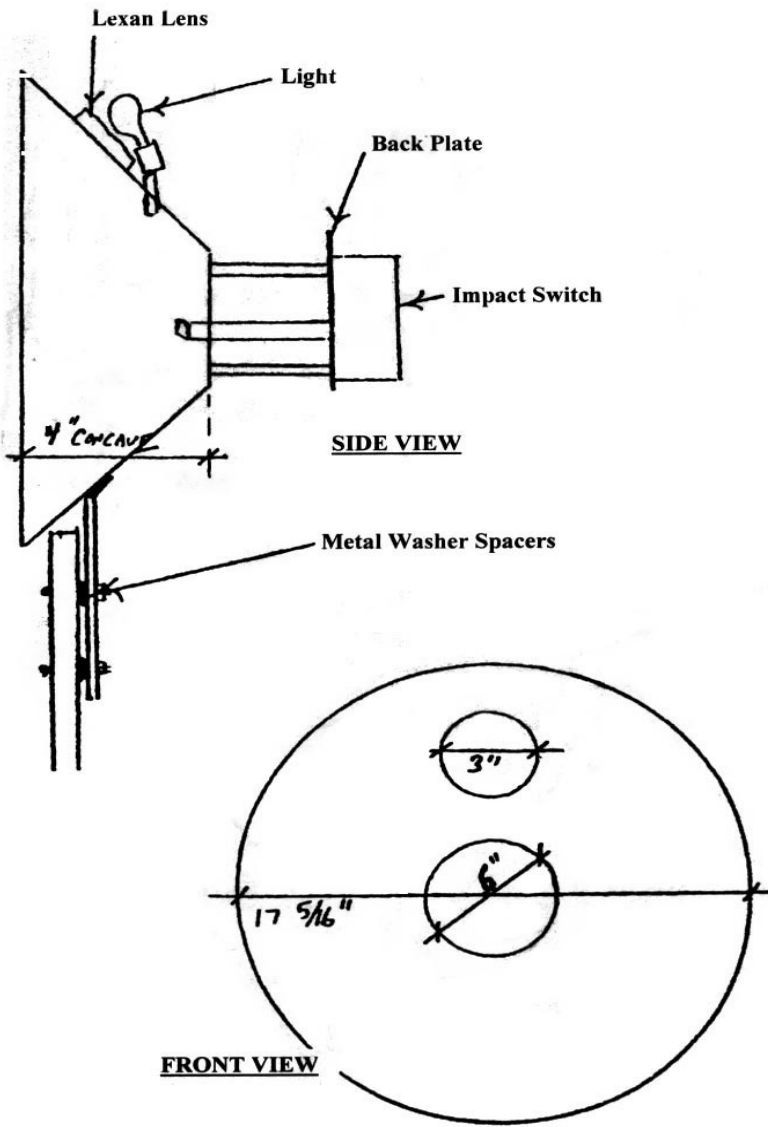


Illustration "K" (Balloon Target)



## **PART VII HISTORY OF OFFICERS OF W.F.D.A.**

	<b>CHAIRMAN</b>	<b>SECRETARY</b>	<b>TREASURER</b>
76/77	Gil Guerra Sr.	Barry Hunter	Jacqui Dyer
78/79	Gil Guerra Sr.	Ted Blocker	Johnny Owen
80/81	Gene Cozzitorto	George Fair	Ron Phillips
82/83	Gene Cozzitorto	George Fair	Ron Phillips
84/85	Richard Plum	Harlan Smith	Louise Nelson
86/87	Richard Plum	Harlan Smith	Louise Nelson
88	Richard Plum	Rose Guerra	Charlene McMahon
89	Richard Plum	Jay Faughn	Charlene McMahon
90/91	Gene Cozzitorto	Jay Faughn	Charlene McMahon
92/93	Richard S. Hughes	Cal Eilrich	Johnny Owen
94/95	Cal Eilrich	Ron Bright	Richard S. Hughes
96/97	Cal Eilrich	Ron Bright	Ron Phillips
98/99	Ray Thielke	Ron Bright	Ron Phillips
00/01	Larry Jelinek	Ron Bright	Suellen Heath
02/03	Gil Guerra Sr.	Linda Faughn	Suellen Heath
04/05	Gil Guerra Sr.	Linda Faughn	Bob Bussinger
06/07	Frank Lawton	Cheryl Short	Miles Miller
08/09	Jim Yager	Mike Pantano	Miles Miller
10/11	Dave Livingston	Dan Qualls	Miles Miller

THIS RULEBOOK IS DEDICATED TO THOSE WHO HAVE CARED ENOUGH TO COMMIT THEIR TIME AND EFFORT TO THE FURTHERANCE OF THE SPORT OF FAST DRAW OVER THE YEARS. OUR RULES AND BY-LAWS ARE THE RESULT OF OVER 45 YEARS OF EVOLUTION OF TRAIL AND ERROR. THE ABOVE INDIVIDUALS ARE THE HEART OF THE REASON THAT FAST DRAW STILL EXISTS TODAY.

**THANKS TO ALL WHO HAVE SERVED IN THE CAPACITY OF VICE-CHAIRMAN AND HAVE REPRESENTED ALL OF THE AREAS AND WRITTEN REPORTS AND ARTICLES OVER THE YEARS. EVEN THOUGH WE CAN'T LIST ALL OF THEM, THEIR SERVICE IS APPRECIATED.**

## PART VIII ARCHIVE OF CHAMPIONS

The following list is something that has been in the working for several years. Ron Bright spent many hours compiling this list by checking back through hundreds of publications from the Mid-Western Fast Draw Association, The Western Fast Draw Association, The W.F.D.A. and many other sources. It is an attempt to record for all time forward the Champions of the Sport of Fast Draw. This list may not be complete but it is a place to start. We sincerely hope that future Officers will maintain, add to, and refine it. It is not possible to list all winners of all contests, so we have only included Chairman Sanctioned State Championships, Regional, National, World and All-Around World Championships. Enjoy!

- 55-57 National – Dee Woolem
- 58 Tombstone – Slim O’Conner / National – Dee Woolem
- 59 Tombstone – Thell Reed / National – Clot Sahara W&D – Gary Freymueller / National - Jack Casey
- 60 Tombstone – Bob Shan / National Clot Sahara W&D – Jack Simms
- 61 Tombstone – Chuck Reed / Colt Sahara W&D – Fred Stieler / National Wax – Claude Gosney / Mid-America – Jerry Booher
- 62 Tombstone – John Amos / Colt Sahara W&D – Vance Anderson & Ruth Savage / World – Norm Smith & Marge Kneezel
- 63 Tombstone – Dick McGaugh
- 64 Tombstone – W&D George Narasaki – S/W Joe Genson – S/B Joe Benson / Mid-Continent – Charlie Forester & Micky Bodkins / Western States – Al Brian
- 65 Tombstone – Joe Benson / World – Bob Graham & Marilyn Milicevic / Mid-America – Ron Bright & Micky Bodkins / Mid-Continent – Pat McMahon & Micky Bodkins
- 66 Tombstone – Al Brian / National – Bob Graham / World – Bob Graham & Merrill Graham / Mid-America – Ron Phillips & Pam Plum
- 67 Tombstone – Stan Sweet / National – Claude Gosney / World – Ron Bright & Cecil Jennings / World Thumbing – Claude Gosney / Mid-America – Larry Tomlinson
- 68 Tombstone – Jim Standridge & Jean Bussinger / Mid-America – Dave Westerman & Elsie Burger
- 69 Tombstone – Dick Plum & Elizabeth Adam / World – Ron Bright & Merrill Graham / Mid-America – Ron Bright & Joyce Bright / Western States – Richard Garner & Jean Bussinger
- 70 Tombstone – Bob James & Joyce Tryon / National – Ron Phillips & Jean Bussinger / World – Richard Garner & Virginia Reese / U.S Open – Bob Arganbright & Kathy Hamilton / Mid-America – Ron Bright & Diane Toblesky / Western States – Paul Christensen & Jean Bussinger

- 71 Tombstone – Bob James & Sharon Crenshaw / National – Bob James & Helen Cook / World – Jack Jazinski & Millie Jazinki / Mid-America – Cal Eilrich & Kay Arganbright / Western States – Al Brian & Dee Wiwchar
- 72 Tombstone – Wes Flowers & Joyce Tryon / National – Dale Crenshaw & Virginia Reese / World – Cal Eilrich & Virginia Reese / South West National – Ron Bright & Linda Guerra / Great Lakes National – Ron Phillips & Elsie Place / Canadian Nationals – Cal Eilrich & Dee Wiwchar / Mid-America – Bob Arganbright & Kay Arganbright / Western States – Paul Christensen & Virginia Reese
- 73 Tombstone – Wes Flowers & Monica James / National – Stan Sweet & Linda Guerra / World – George Reese & Virginia Reese / Mid-America – Cal Eilrich & Elsie Place
- 74 Tombstone – Ron Phillips & Doreen Ballard / National – Gil Guerra Jr. & Jean Blocker / World – Mel Stockwell & Linda Guerra / Mid-West Nationals – Bob Huber Sr. & Sharon Jelinek / Canadian Nationals – Gil Guerra Sr. & Lucy Fair / Mid-America – Bob Arganbright & Alice Warren / CA National – Mel Stockwell & Linda Guerra
- 75 Tombstone – Gil Guerra Jr. & Linda Guerra / National – Bob Graham & Fran Turner / World – Gil Guerra Jr. & Linda Guerra / Western States – Jack Fritz & Linda Guerra
- 76 Tombstone – Ron Phillips & Joyce Tryon / National – Bill Waller & Lucy Fair / World – Bob Graham & Virginia Reese / Western States – Cal Eilrich & Joyce Tryon
- 77 Tombstone – Ron Phillips & Nancy Waller / National – Mel Stockwell & Linda Guerra Schmidt / World Index – Ron Phillips & Carrol Crussel / World Elimination – Gil Guerra Jr. & Linda Guerra Schmidt / Western States – Gene Cozzitorto & Virginia Reese
- 78 Tombstone – Ron Phillips & Doreen Ballard / World Index – Mel Stockwell & Lucy Fair / Mid-America – Al Miles & Justy Van Beber / International – Ron Phillips & Monica James
- 79 Tombstone – Gary Tryon & Doreen Ballard / World Index – Jim Standridge & Dianne Graham / U.S. Open Index – Larry Lalouette & Joyce Tryon / Mid-West Nationals – Ron Phillips & Doris Rogers
- 80 Tombstone – Ron Phillips & Nancy Waller
- 81 All-Around World – Cal Eilrich & Lucy Fair (tie) Joyce Tryon / World Index – Ron Phillips & Lucy Fair / Canadian Nationals – Cal Eilrich & Lucy Fair / Pacific Coast – Cal Eilrich & Lucy Fair / Western States – Cal Eilrich & Nancy Hunter / Mid-Western States – Ron Phillips & Doreen Ballard
- 82 All-Around World – Cal Eilrich & Lucy Fair
- 83 World Index – Bob Graham & Linda Guerra Schmidt
- 84 World Index – Bill Waller & Doreen Ballard
- 85 World Index – Stan Sweet & Carol Cozzitorto
- 86 National Index – Bob James & Doreen Ballard

- 87 World Elimination – Ernie Hill & Doreen Ballard
- 88 World Index – Stan Sweet & Doreen Ballard / World Traditional  
Index – Bob Arganbright & Charlene McMahon / World Thumbing –  
Tom Wildenauer / Western States – Gil Guerra Jr. & Doreen Ballard
- 89 International – Stan Sweet & Dinah Eilrich
- 90 World Open Elimination – Ernie Hill & Joyce Tryon / International –  
Ron Phillips & Linda Faughn.
- 91 Tombstone – Cal Elrich & ? / Texas State – Ron Phillips & Carol  
Cozzitorto
- 92 World Traditional Elimination (Deadwood) – Cal Eilrich & Linda  
Faughn / World Index – Gil Guerra Jr. & Rita Guerra Hudson
- 93 All-Around World – Cal Eilrich & Dinah Eilrich / World Index – Cal  
Eilrich & Dinah Eilrich / World Traditional Elimination (Deadwood)  
Tony Williams & Cathy Dobson Coy / World Open Elimination (Roy  
Rogers) – Ernie Hill & Joyce Tryon / Tombstone Nationals – Cal  
Eilrich & Dinah Eilrich / Texas State – Cal Eilrich & Dinah Eilrich /  
California State – Tony Williams & Joyce Tryon
- 94 All-Around World – Cal Eilrich (tie) Gil Guerra Jr. & Dinah Eilrich /  
World Index – Cal Eilrich & Dinah Eilrich / World Traditional  
Elimination (Deadwood) – Gil Guerra Jr. & Joyce Tryon / World  
Open Elimination (Roy Rogers) – Ernie Hill & Joyce Tryon /  
Tombstone Nationals – Ron Phillips & Dinah Eilrich / International  
Elimination – Cal Eilrich & Dinah Eilrich / Western States – Cal  
Eilrich & Jennifer Guerra / Canadian National – Howard Darby & Pat  
Weatherby / Texas State – Ron Bright & Dinah Eilrich
- 95 All-Around World – Cal Eilrich & Dinah Eilrich / World Index – Cal  
Eilrich & Dinah Eilrich / World Elimination (Deadwood) – Cal Eilrich  
& Linda Faughn / Tombstone Nationals – Cal Eilrich & Jean  
Bussinger / U.S. Invitational – Ron Phillips & Rita Guerra / Canadian  
National – Cal Eilrich & Pat Weatherby / Texas State – Cal Eilrich &  
Dinah Eilrich / Wild West – Gil Guerra & Joyce Tryon
- 96 All-Around World – Cal Eilrich & Dinah Eilrich / World Index – John  
LeBlanc & Joyce Tryon / World Elimination (Deadwood) – Bob  
Bussinger & Joyce Tryon / Tombstone Internationals – Cal Eilrich &  
Dinah Eilrich / U.S. Invitational – Cal Eilrich & Dinah Eilrich /  
National Elimination – Gil Guerra Jr. & Susie Vonfeldt / Canadian  
National – Cal Eilrich & Monica James / Texas State – Cal Eilrich &  
Dinah Eilrich / Wild West – Bob Arganbright & Dinah Eilrich
- 97 World Elimination (Deadwood) – Bob Bussinger & Jan Barry / World  
Wax Elimination – Ron Phillips & Linda Faughn / National  
Elimination – Ron Phillips & Jean Bussinger
- 98 World Elimination (Deadwood) – Bob Bussinger & Linda Faughn  
National Elimination – Ed Thielke & Joyce Tryon

- 99 National Elimination Ore.– Greg Danielson & Joyce Tryon /Wild West Worlds, AZ. Gary Tryon & Joyce Tryon/ World Elimination, CO. Mark Hullen & Linda Faughn/Texas State-Bob Graham & Joyce Tryon.
- 00 Wild West World Index, AZ-Ron Phillips & Joyce Tryon/ National Elimination, Ore-Bob Mernickle & Peggy Franks/ World Elimination, CO-Richard Parmentier & Nicole Franks/ National Index, Ore. Ray Thielke & Nicole Franks.
- 01 Twister World Index, Neb-Greg Danielson & Cel Jones / National Elimination, Ore. - AA Ted Blocker & Nicole Franks A-Gary Tryon & Geneta Faw B-Ralph Howell & Carla Howell / World Wax Elimination- Deadwood AA - Howard Darby & Nicole Franks A-Tye Faw & Anita Burnham B-Gary Adrian & Carla Howell/ National Index, ore-John LeBlanc & Anita Burnham/ No. of the 49th S/B Elimination, Can. AA-Howard Darby & Nicole Franks A-Tye Faw & Anita Burnham B-Bill Caravello & Shauna Frey / Montana S/B Elimination AA-Howard Darby & Joyce Tryon A-Tye Faw & Anita Burnham B- Peter Garibaldi & Carla Howell.
- 02 Wild West World Index, AZ-Harrold Kelley & Sherry Kelley No. of the 49th S/B Elimination, Can. AA-Howard Darby & Nicole Franks A-Jim Yager & Anita Burnham B- Thomas Guerra & Linda Benediction/ Montana S/B Elimination AA-Howard Darby & Alanna Blinn A- Ron Martinez & Anita Burnham B-Ralph Howell & Carla Howell/ Fastest Gun Alive, Ore. Gil Guerra Jr. & Nicole Franks/Wild Bill Hickok Worlds S/W Elimination, Deadwood-AA Greg Danielson & Peggy Franks A-Jim Standridge & Anita Burnham B-Thomas Guerra & Carla Howell/ Canadian Fast Draw wax Elim. Championship AA-Howard Darby & Nicole Franks A-Wayne Andrews & Anita Burnham B-Randy McCulloch & Brenda Gay.
- 03 Wild West World Index, AZ-Howard Darby & Sherry Kelley/ World S/B Montana Elimination AA-Howard Darby & Nicole Franks A-Bob Arganbright & Monica James B-Peter Garibaldi & Carla Howell Fastest Gun Alive, Ore.-Howard Darby & Peggy Franks/Canadian Fast Draw Wax Elimination AA-Howard Darby & Nicole Franks A-Don Mowery & Anita Burnham B-Randy McCulloch & Linda Benediction.

## LOADING FAST DRAW AMMUNITION

One of the most unique parts of Fast Draw is our ammunition. We can hold contests and practice just about anywhere. You can turn your garage or basement into your personal shooting range and enjoy many hours of practice. With wax bullets you can effectively practice any event in the sport and travel to any contest and feel confident in your ability. Let's explore various Wax and Blank cartridges.

### WAX CARTRIDGES

There are several brands manufactured that are accepted in W.F.D.A. competition. Some shooters make their own for practice by melting paraffin wax and pouring it into a pan about 1/2" thick and letting it cool just enough so that a shell casing can be pushed in and out repeatedly, then it is put in a freezer and when hard it'll render a good quantity of wax bullets. Most shooters buy them commercially made even for practice. You'll find them available in the classified Section of the monthly "Top Gun" Magazine. Wax is powered by ... No gun powder! Only pistol primers, shotgun primers, or .22 Short Black Power Blank.

Pistol primers are popular for practice, but are rarely used in competition; sometimes they won't stop the timing devices. Flash holes are generally drilled out so that the primer will not backup causing the cylinder not to spin.

Most shooters bore out the back of the shell casings so that they accept shotgun primers; this is the most common wax cartridge used in practice and competition. They should be loose enough so that no tools are required to prime or de-prime, in fact many use the same 6 casing over and over.

.22 Short Black Powder Blanks are the most powerful propellant allowed for wax bullets. There have been .22/.45 casings manufactured in which the primer hole is offset so that it makes the rim-fire .22 blanks work in the center-fire .45. Some shooters use .22 caliber guns with the front of the cylinder bored out to .38 caliber with a .38 barrel installed. These are the fastest way to propel wax bullets.

**WARNING:** Shotgun primers propel wax at 600-800 fps. and .22 blanks at 1000 plus fps., They should be handled with the respect due any firearm, even though wax bullets lack mass, they can do great harm, to various parts of the body, **Never point a firearm at anything you're not willing to destroy!**

## BLANK CARTRIDGES

Blank Cartridges for Fast Draw competition can be constructed from any gunpowder bought over the counter. There are as many recipes for loading blanks than there are shooters. The reason there are so many variations is because in Fast Draw you must break a balloon with the muzzle blast of your blank. Therefore, Championship Titles and Prize Money are riding on your ability to load a potent blank. Most of the Top Guns would never let anyone load their blanks besides themselves.

Blank events are the fastest events in Fast Draw, because a properly loaded blank can create a 2 foot plus pattern at 8'. There are two distinct strategies for blank loads, one that provides the most effective pattern, and one that provides for the fastest means to break the balloon. For the later some shooters use all kinds of concoctions of hot burning pistol powders and slow burning rifle powders.

This article is concerned with helping new shooters get information they need so we will only cover probably the most basic blank load. The Black Powder Blank.

First, start by acquiring some .45 Long Colt cartridges and drill the primer hole out to 1/8", this enables the kicker powder to ignite better, prevents primers from backing out and jamming your cylinder, and still keeps the anvil in the primer from becoming a projectile. Prime the casing with a large pistol primer, stay away from magnum primers because they are harder to detonate because of a thicker hull. Winchester and Remington are the easiest to press into the castings, CCI's are good primers but the hull is thicker making them harder to install and detonate. **Important:** Do not let any oil come in contact with primers, it kills them. Even body oil from your fingers can eventually seep into them.

The two types of Black Powder used are 4F and 1F. 4F is the finest and ignites the fastest. 1F is course and ignites slower. Use 10 grains of 4F as a "Kicker" so that the load ignites quickly and evenly, pack it down tightly with a 3/8" brass rod, **Do not pound it with a hammer! That can cause the primer to ignite and ruin your day!** Go through this process with all of the blanks you wish to load and then place them in a large flat pan moving them all together. Then open a can of 1F and pour it over the casings until full. Then pick them up one at a time and hold with your forefinger over the top and your thumb on the bottom and tap the side of the case with a spoon until you feel the powder settle. Adjust the powder height to 1/8" under the rim and then press on a wad. If you are crunching your powder the casing is to full. You don't want to turn your 1F into 4F because you are relying on the course powder to last long enough to break the balloon. For wads use a 1/2" leather punch and punch wads out of an empty milk carton. This works well to keep moisture out. Also recommended is finger nail polish as a sealer.

The applicator works well to make sure the edges are sealed. Don't over do the sealer, not only is that against the rules, but it can cause a hole in your pattern.

**Always** wear earplugs when shooting, especially blanks. They are also recommended for wax, sustained wax shooting can damage your hearing also.. Fast Draw competitors can be disturbed easily by noise and it will make you less susceptible to "jumping the light" and will improve your concentration. Some people have trouble adapting to earplugs, practice with them and get use to them.

## **HELPING OUT AT CONTESTS**

Your help is always appreciated at Fast Draw Contests no matter how long you have been shooting. There are always things that need to be done. Hosts of contests, officers, and other contest officials all volunteer their services. You'll learn more about the sport and the inner workings of competition. Whether it's stuffing balloons, being a line judge, or helping with scores, we all depend on each other to make it work. You'll find Fast Draw shooters are a friendly and close knit group because of this. Don't be intimidated by not knowing how to hand judge or keep score, somebody will always be glad to show you. The best way to learn is by experience.

## **START A FAST DRAW CLUB**

Every area needs a leader. If there are no clubs in your area, contact your Vice-Chairman for assistance on getting one started. You'll need to find a place to shoot indoors in the evenings. Meeting every two weeks on a weeknight is the best situation for getting new members involved. For instance, the 1<sup>st</sup> and 3<sup>rd</sup> Tuesday Night of the month. That way everyone knows the schedule. Most local papers will be glad to run an article about your club and regularly advertise your club nights, since you'll probably be a non-profit organization.

## **BUILD THE SPORT OF FAST DRAW, BUILD A CLUB!**

**WORLD FAST DRAW ASSOCIATION, INC.**

“The Fastest and Safest Gun Sport in the World”

**SPONSORSHIP CONTRACT**

This document constitutes a three party contract between The World Fast Draw Association, herein referred to as The WFDA; \_\_\_\_\_, herein referred to as The Host; and \_\_\_\_\_, herein referred to as The Sponsor.

The WFDA will sanction this event as \_\_\_\_\_, on the date of \_\_\_\_\_, in the location of; \_\_\_\_\_

\_\_\_\_\_.

The WFDA will not sanction any tournaments that conflict with this. Title or date as set forth in The WFDA Rules & By-laws. The WFDA will provide an officer to act as Chief Official to insure that all competition rules are followed. This contest will be advertised in the WFDA’s monthly publications. The WFDA also agrees to provide \$500,000 of Liability Insurance, under our blanket policy. Copies of this policy are available upon request.

The host shall be bound to run this tournament according to the WFDA Rules & By-laws to the best of their ability. The Host shall read and understand the Rulebook especially all Safety Rules, Competition Rules, and Part V Host Requirements. The Host agrees to run the contest as advertised, have timing equipment in good Working order, and supply an ample staff to administrate this event. The Host will contact the local police department and inform them of the event and secure any permits, if necessary. Only wax bullets and blanks are to be allowed in the shooting area, No Live Ammo. The Host will provide adequate backstops in accordance with WFDA Rules. The Host shall have all prize money, trophies and other advertised awards available for presentation immediately after completion of the competition.

The Sponsor agrees to provide the sum of \$ \_\_\_\_\_ to the Host no later than \_\_\_\_\_. The Sponsor agrees to provide a contest site acceptable to the Host under the guidelines as set forth in The WFDA Rulebook. The Sponsor shall provide an A/C power source acceptable to the Host.

Please fill out appropriate spaces and sign this contract. Upon receipt of this contract, prize structure, dates, events, and sanction fee. The Sanction will be granted by the WFDA. After the WFDA approves this contract a copy will be sent to all parties. Please include names, addresses, and phone numbers of all parties. The Sponsor or Host may cancel a sanction no later than ninety (90) days prior to the scheduled contest, in writing, without recourse. Sanction Fees are non-refundable.

**WORLD FAST DRAW ASSOCIATION, INC.**

“The Fastest and Safest Gun Sport in the World”

**SPONSORSHIP CONTRACT con't...**

ADDITIONAL TERMS:

---

---

---

---

---

---

---

---

---

SPONSOR:

---

Contact:

---

Address:

---

City / State / Zip:

---

Phone: \_\_\_\_\_ Fax: \_\_\_\_\_

---

HOST:

---

Address:

---

---

City / State / Zip:

Phone: \_\_\_\_\_ Fax: \_\_\_\_\_  
\_\_\_\_\_

World Fast Draw Association

Sanctioning Officer:

\_\_\_\_\_  
Title:

\_\_\_\_\_  
Address:

\_\_\_\_\_  
City / State / Zip:

Phone: \_\_\_\_\_ Fax: \_\_\_\_\_  
\_\_\_\_\_

Sponsor Signature:  
\_\_\_\_\_

Host Signature:  
\_\_\_\_\_

Officer Signature:  
\_\_\_\_\_

**NOTES**



